

# HILO V2 TECHNICAL SPECIFICATION

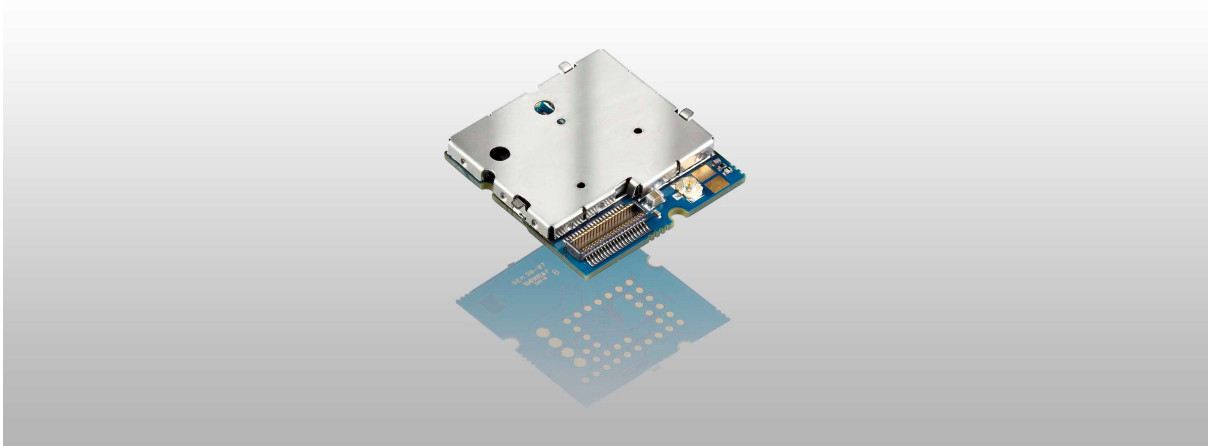

~ Freedom of speech  
for smart machines

**FICHE RECAPITULATIVE / REVISION HISTORY**

<b>Ed</b>	<b>Date</b> <i>Date</i>	<b>Référence</b> <i>Reference</i>	<b>Pages modifiées / Changed pages</b>	<b>Observations</b> <i>Comments</i>
1	16/12/2010	URD1- OTL 5635.2- 013 / 72398		Creation du document / <i>Document creation</i>
2	11/03/2011	URD1- OTL 5635.2- 013 / 72398	8,16	Power consumption table correction.

## SOMMAIRE / CONTENTS

<b>1.</b>	<b>INTRODUCTION</b> .....	6
1.1	PRODUCT CONCEPT.....	6
1.2	STANDARDS.....	6
1.3	TERMS AND ABBREVIATION.....	7
1.4	CONVENTIONS.....	8
1.5	PRODUCT FEATURES OVERVIEW.....	8
<b>2.</b>	<b>BLOCK DIAGRAM</b> .....	10
<b>3.</b>	<b>FUNCTIONAL DESCRIPTION</b> .....	11
3.1	SIM.....	11
3.1.1	SIM card interface.....	11
3.1.2	SIM card connection.....	11
3.2	AUDIO.....	12
3.2.1	Analog Audio.....	12
3.2.2	Digital Audio.....	12
3.3	PWM.....	13
3.4	DATA.....	13
3.4.1	Data services.....	13
3.4.2	UART: V24.....	13
3.4.3	UART0 (trace interface).....	14
3.5	SPARE I/O.....	14
3.6	RF BURST INDICATOR.....	14
3.7	POWER MANAGEMENT.....	15
3.7.1	SLEEP MODES.....	15
3.7.2	Power supply and power consumption.....	15
3.7.3	VGPIO.....	17
3.7.4	VBACKUP.....	17
3.8	DATA / COMMAND MULTIPLEXING.....	18
<b>4.</b>	<b>PINOUT</b> .....	19
4.1	I/O CONNECTOR PIN ASSIGNMENTS.....	19
4.2	POWER DOMAINS AND UNUSED PINS POLICY.....	21
<b>5.</b>	<b>ELECTRICAL SPECIFICATION</b> .....	22
5.1	VBAT.....	22
5.2	VGPIO.....	23
5.3	VBACKUP.....	23
5.4	VSIM.....	24
5.5	DIGITAL INTERFACE.....	24
5.6	POK_IN.....	24
5.7	SIM.....	25
5.8	PWM.....	25
5.9	AUX_ADC.....	26
5.10	UART1.....	26
5.11	AUDIO SIGNALS.....	27
5.11.1	Audio Inputs.....	27
5.11.2	Audio Outputs.....	27
5.12	RF SIGNALS.....	27
5.12.1	Load mismatch.....	27
5.12.2	Input VSWR.....	27
5.12.3	Antenna matching network.....	27



<b>6.</b>	<b>ENVIRONMENTAL SPECIFICATION</b>	28
6.1	NORMAL TEMPERATURE RANGE	28
6.2	EXTENDED TEMPERATURE RANGE	28
6.2.1	Sensitivity	28
6.2.2	Transmission characteristics	29
6.2.3	Power consumption	29
6.3	OUT OF OPERATIONAL RANGE	29
<b>7.</b>	<b>ESD</b>	30
<b>8.</b>	<b>MECHANICAL SPECIFICATION</b>	31
8.1	PHYSICAL DIMENSIONS	31
8.2	ASSEMBLY	33
8.3	TERMINAL ASSIGNMENTS	35
8.3.1	Board to Board connection	35
8.3.2	Antenna connection	36
<b>9.</b>	<b>ORDERING AND CONTACT INFORMATION</b>	38
9.1	PART NUMBERS	38
9.2	CONTACT	38
<b>10.</b>	<b>REFERENCE DOCUMENTS</b>	39



## 1. INTRODUCTION

This document describes the hardware interface of the Sagemcom HiLo V2 module that connects to the cellular device application and the air interface.

### 1.1 PRODUCT CONCEPT

The HiLo V2 module is one of the smallest available GPRS (multislot class 10) quad band module of the market with an industrial connector. The target application is the Machine to Machine (M2M) market including automotive, AMM (Automatic Metering Management), tracking system, Alarm, etc. Despite its small size and cost, it has comprehensive GSM/GPRS services, data and IP features.

In addition to its size it has the following outstanding characteristics:

- Automotive temperature range: -40 °C to +85 °C
- Minimum low power consumption in idle mode: 1.25 mA in DRX5
- Full automotive qualification regarding ISO16750 standards
- High input voltage range: 3.2 V to 4.5 V
- Digital PCM audio
- Fully form factor compliant with the HiLo
- Pin to pin compliant with the main HiLo pins (power supplies, UART, Sim and audio pins)

As other Sagemcom GSM/GPRS/EDGE modules, it has a full set of AT commands as well as analogue audio interface [1].

In addition to the HiLo V2 module a complete development kit can be provided to customers.

### 1.2 STANDARDS

This product with its evaluation board has been approved to comply with the directives and standards listed below:

#### Directives

99/05/EC	« Directive of the European Parliament and of the council of 9 March 1999 on radio equipment and telecommunications terminal equipment and the mutual recognition of their conformity », in short referred to as R&TTE Directive 1999/5/EC
2004/108/EC	Directive on electromagnetic compatibility
2006/95/EC	« Directive on electrical equipment designed for use within certain voltage limits » (Low Voltage Directive)
2002/95/EC	RoHS Directive
95/94/EC	Automotive EMC Directive
FCC part 2	Frequency allocations and radio treaty matters
FCC part 15	Radio frequency devices subpart B – Unintentional Radiators
FCC part 22	Public mobile services subpart H – Cellular Radio Telephone Service
FCC part 24	Personal Communications Services, PCS (Narrow band PCS 901-902, 930-931, 940-941 MHz. Broadband PCS 1850-1990 MHz)

### Standards of type approval

3GPP TS 51.010-1	« Digital cellular telecommunications system (Phase 2); Mobile Station (MS) conformance specification »
ETSI EN 301 511	« Candidate Harmonized European Standard (Telecommunications series) Global System for Mobile communications (GSM); Harmonized standard for mobile stations in the GSM 900 and DCS 1800 bands covering essential requirements under article 3.2 of the R&TTE directive (1999/5/EC) (GSM 13.11 version 7.0.1 Release 1998) »
GCF-CC ver 3.28.0	Global Certification Forum - Certification Criteria
PTCRB ver 3.13.0 ETSI EN 301 489-7	PCS Type Certification Review Board « Candidate Harmonized European Standard (Telecommunications series) Electro Magnetic Compatibility and Radio spectrum Matters (ERM); Electro Magnetic Compatibility (EMC) standard for radio equipment and services; Part 7: Specific conditions for mobile and portable radio and ancillary equipment of digital cellular radio telecommunications systems (GSM and DCS) »
EN 60 950	Safety of information technology equipment

### Requirements of quality

IEC 60068	Environmental testing
ISO 16750	Road Vehicles – Environmental conditions and testing for electrical and electronic equipment. ISO 16750 is used as a guide line to qualify the HiLo module.

## 1.3 TERMS AND ABBREVIATION

ADC	Analog to Digital Converter
CODEC	Coder-Decoder
CTS	Clear To Send
DCS	Digital Communications System
DSR	Data Set Ready
DTR	Data Terminal Ready
EGSM	Enhanced GSM
ESD	Electrostatic Discharge
ETS	European Telecommunication Standard
GSM	Global System for Mobile communication
GPRS	General Packet Radio Services
IC	Integrated Circuit
IEEE	Institute of Electrical and Electronics Engineers
I/O	Input / Output
ISO	International Standards Organization
ITU	International Telecommunication Union
JTAG	Joint Test Action Group
Kbps	kilobit per second
LCD	Liquid Crystal Display
LED	Light Emitting Diode
Mbps	Megabit per second
PBCCH	Packet Broadcast Channel
PCB	Printed Circuit Board
PCS	Personal Communication System
PWM	Pulse Width Modulation
RAM	Random Access Memory

RF	Radio Frequency
RI	Ring Indication
RMS	Root Mean Square
RTS	Ready To Send
RX	Reception
SIM	Subscriber Identification Module
SMS	Short Message Service
TBC	To Be Confirmed
TBD	To Be Defined
TX	Transmission
UART	Universal Asynchronous Receiver and Transmitter
USSD	Unstructured Supplementary Service Data

## 1.4 CONVENTIONS

Throughout this document, DTE (Data Terminal equipment) indicates the equipment which masters and controls the module device HiLo V2 by sending AT commands via its serial interface.

DCE (Data Communication Equipment) indicates the module device HiLo V2.

## 1.5 PRODUCT FEATURES OVERVIEW

Temperature range	Normal range: -20°C to +80°C (fully compliant) Extended range: -40°C to -20°C and +80°C to +85°C (fully functional) Storage: -40°C to +85°C
Weight (in g)	4.3g (typical)
ESD	ESD protection < 2 kV
Physical dimensions	27x27x3.6 mm (typical)
Connection	40 pins connector + 1 RF connector + 1 pair of antenna pad
Power supply	3.2V to 4.5V range, 3.7V nominal
Power consumption*	Off mode: 35 µA typical Minimum Stand-by mode: 1.25 mA in DRX5 Communication mode (at Pmax): GSM --- 220 mA DCS --- 170 mA
Battery charge management and interface	No battery charge management is included.
Antenna	No antenna is included in the module.
Frequency bands	Sagemcom module supports GSM850, EGSM900, DCS1800, PCS 1900
Voice codec	Half Rate, Full Rate, Enhanced Full Rate, Adaptive Multi Rate
GSM class	Small MS
Transmit power	Class 4 (2W) for GSM850 / EGSM900 Class 1 (1W) for DCS1800 / PCS1900
Supported SIM card	3V and 1.8V SIM cards

\* The power consumption is highly dependent on customer's product design and environment of GSM Module

SIM slot	Signals for the management of the SIM card are provided on 40 pins connector
PWM	Signals for LED, vibrating device and Buzzer management are provided on the PWM interface
Audio up-link	1 single end input is provided for microphone
Audio down-link	1 differential output is provided for non stereo earphone
Audio PCM	4 lines for the digital audio bus
UART interface with flow control	Up to 115.2 Kbps with auto-bauding. Full flow control signals (+2.8V) are provided on 40 pins connector. A reference schematic to build the RS232 interface is provided in the HiLo V2 application note.
UART trace interface	Up to 115.2Kbps trace RX-TX UART (Only for Sagemcom use)
Data/command multiplexing	Software management of data/command multiplexing on the serial link UART
Data services	GPRS, CSD, Fax
Supplementary services (supported via AT commands)	Caller Line Identification, Call Waiting, Call Hold, Call Forwarding, Multiparty, Call Barring, Advice of Charge, STK, USSD, CPHS
Power on pin	Available, low level active
Reset pin	Available, low level active
General purpose I/Os pin	3 GPIO + 1 ADC available
RF Transmit Indicator	1 IO indicating the RF power amplifier activity, high level active.
GSM release	R99
GPRS	SMG 31bis, Multi slot class 10, class B terminal, PBCCH support
GSM/DCS certification GCF-CC	V3.29.0
PCS certification	NAPRD03 (V3.13.0)

## 2. BLOCK DIAGRAM

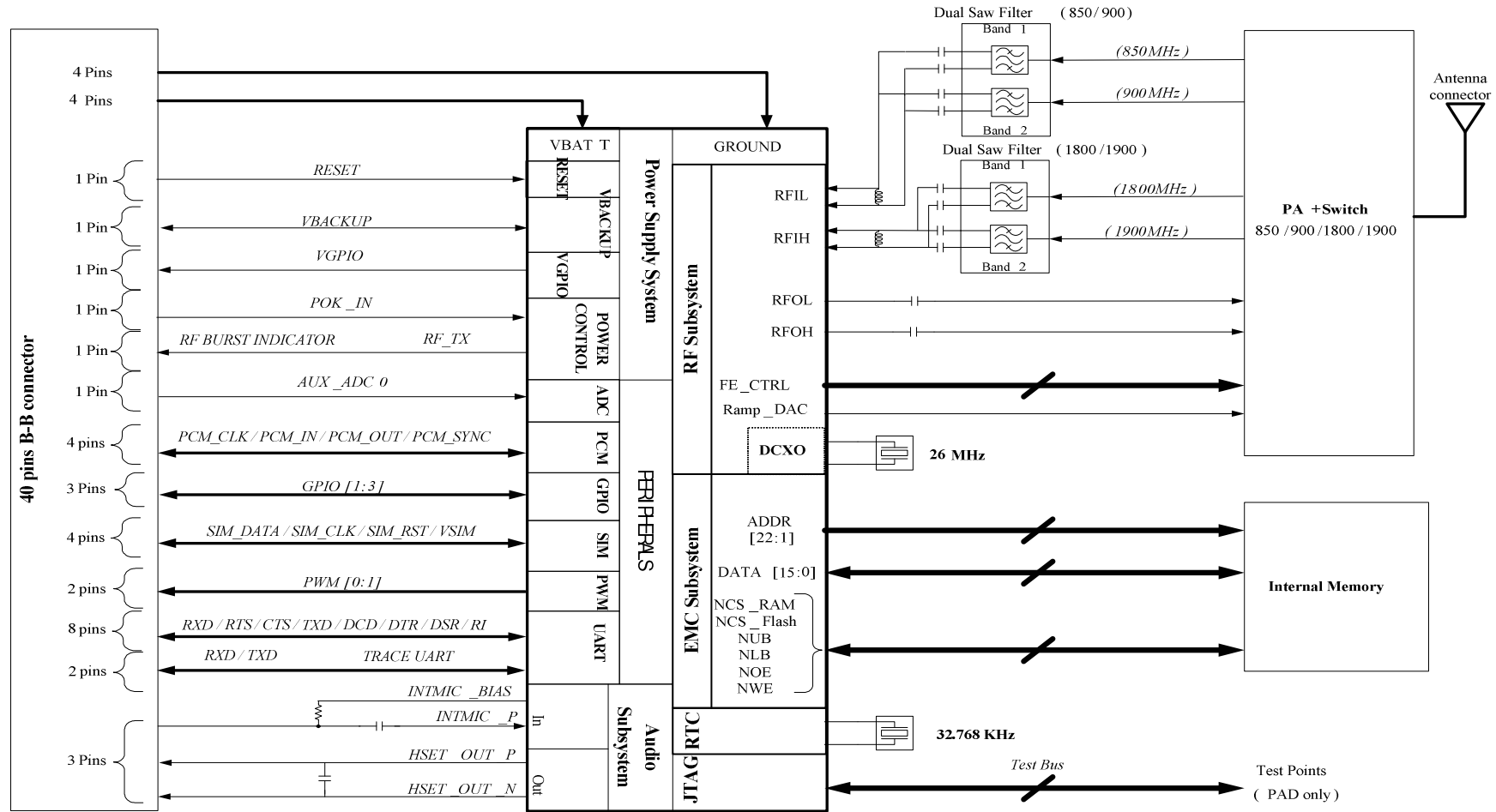

Figure 1: HiLo V2 block diagram



### 3. FUNCTIONAL DESCRIPTION

#### 3.1 SIM

##### 3.1.1 SIM card interface

The SIM card interface is compatible with the ISO 7816-3 IC card standard on the issues required by the GSM 11.11 Phase 2+ standard and adapts to 3V and 1.8V SIM card.

To prevent SIM card's damages, the power supply of the module has to be turned off before any manipulation on SIM card.

The SIM card interface includes:

- Power supply output (VSIM)
- Bi-direction data signal (SIM\_DATA),
- Clock output (SIM\_CLK)
- Reset signal (SIM\_RST)

Signal	Pin N°	Description
SIM_RST	15	SIM reset, provided by Base-band processor
SIM_CLK	16	SIM clock, provided by Base-band processor
VSIM	24	SIM supply voltage
SIM_DATA	25	SIM serial data line, input and output

##### 3.1.2 SIM card connection

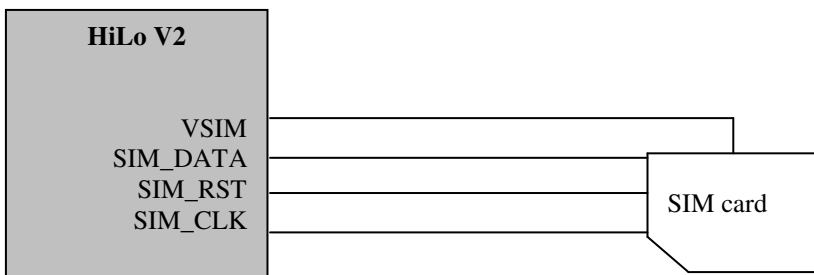

Figure 2: SIM connection

## 3.2 AUDIO

### 3.2.1 Analog Audio

The module supports the following voice codec:

- Half-Rate
- Full-Rate
- Enhanced Full Rate
- Adaptive Multi Rate

Signal	Pin N°	Description
INTMIC_P	20	Single end input signal for microphone
HSET_OUT_P	21	Positive polarized output signal for external speaker
HSET_OUT_N	22	Negative polarized output signal for external speaker

It manages an external microphone (INTMIC\_P) in single end mode and an external earphone (32 Ohms HSET\_OUT\_P/HSET\_OUT\_N) in differential mode.

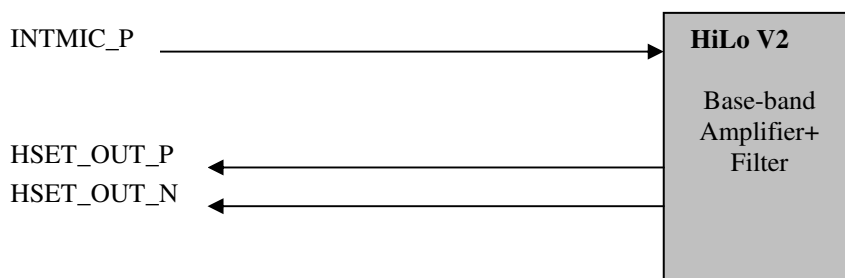

Figure 3: Audio

To ensure proper operation of such sensitive signal, the audio signals should be isolated by ground on DTE layout. Characteristics of microphone, speaker and reference schematic are given in the application notes.

### 3.2.2 Digital Audio

The HiLo V2 M2M module features a PCM interface.

The PCM interface is a High speed full duplex interface that can be used to send and receive digital audio data to external audio ICs.

PCM interface features include the following:

- PCM master mode
- Full duplex operation
- 16 bits PCM data word length
- PCM clock rate 1MHz

Signal	Pin N°	Description
PCM_OUT	33	PCM data output
PCM_IN	34	PCM data input
PCM_SYNC	35	PCM sync signal
PCM_CLK	36	PCM clock signal

### 3.3 PWM

Two PWM interfaces are available on the module. One is general purpose PWM which can be used for driving a vibrating device, keypad backlight or LED. The second one is dedicated to drive a buzzer. All the PWMs can be controlled through AT commands, allowing several periods and duty cycles. More details are given in the AT commands specification.

Signal	Pin N°	Description
PWM0	17	DC PWM
PWM1	23	Buzzer PWM

### 3.4 DATA

#### 3.4.1 Data services

The module supports the following services:

- Built-in data / fax Modem
  - Data over CSD:
    - 9.6 kbps
    - Non transparent mode only
    - V.32 or V.110
  - Data over GPRS:
    - 2 PDP contexts at the same time
    - Internal IP stack: 8 sockets can be opened at the same time. But only 1 FTP socket can be opened at the same time. *E.g.: 1 FTP socket, 1 FTP server and 6 TCP/UDP connections.*

#### 3.4.2 UART: V24

A V24 interface is provided on external pins of the module with the following signals:

- RX/TX
- RTS/CTS
- DSR
- DTR
- DCD
- RI

It supports auto bauding mode and the baud rate up to 115.2 Kbps.

Signal	Pin N°	Description
UART1_DSR	11	UART Data Set Ready
UART1_DCD	12	UART Data Carrier Detect
UART1_TXD	13	UART Transmit
UART1_RTS	27	UART Request To Send
UART1_RXD	26	UART Receive
UART1_CTS	14	UART Clear To Send
UART1_RI	28	UART Ring Indicator
UART1_DTR	29	UART Data Terminal Ready



### 3.4.3 UART0 (trace interface)

A two lines UART interface is provided on external pads of the module with the following signals:

- UART0\_TXD
- UART0\_RXD

This interface is reserved for Sagemcom traces, it can not be used for other purpose, it is strongly recommended to leave this interface accessible on 2 tests points on the Customers PCB.

Signal	Pin N°	Description
UART0_TXD	5	Trace interface UART transmit
UART0_RXD	6	Trace interface UART receive

### 3.5 SPARE I/O

There are 3 GPIO that can be customized easily from the customer's application through appropriate AT commands. And they can be configured as input or output.

Signal	Pin N°	Description
GPIO1	32	General Purpose Input/Output 1
GPIO2	9	General Purpose Input/Output 2
GPIO3	8	General Purpose Input/Output 3

### 3.6 RF BURST INDICATOR

One digital output signal on the 2.8V domain is available to indicate the RF transmissions. It is high level active and can therefore be connected to a transistor and a LED to give a visual indication of the RF activity.

Signal	Pin N°	Description
RF_TX	7	RF power transmitting indicator

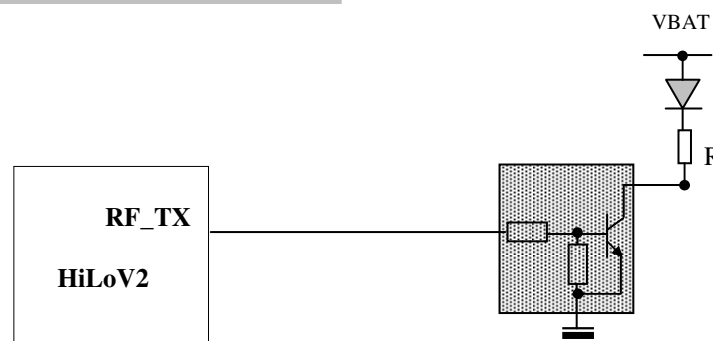

Figure 4: RF TX burst indicator

## 3.7 POWER MANAGEMENT

### 3.7.1 SLEEP MODES

Two kinds of sleep mode are available:

- The “off mode”,
- The “stand-by” mode.

They are described below.

#### 3.7.1.1 Off mode

When the module is in off mode it can not receive any call, it can not receive any AT commands but can be awoken either by its internal clock using AT+CALA [1] or using POK\_IN signal [1]. To go to this mode use AT+\*PSCPOF.

#### 3.7.1.2 Stand-by mode management

There are three stand-by modes management:

- AT+KSLEEP=0  
In this mode the sleep state is controlled by the DTR and by the firmware
  - DTR = 1<sup>†</sup> - The module never goes to sleep mode
  - DTR = 0 - The module goes to sleep mode when it is ready and **can not** be awoken with an AT command. To wake up the module the user must toggle DTR to 1.
 Remark: even in this mode it is possible to use DTR signal to go from data to command mode, however in this case DTR has to be toggled from 1 to 0 then from 0 to 1 (see §3.8)
- AT+KSLEEP=1  
In this mode the sleep state is only controlled by the firmware.  
The module goes to sleep mode when it is ready. The module may be awoken with any character received on the UART. However to be sure to wake up the module the “0x00” character has to be sent.

In both previous modes the power consumption in sleep mode is given in §3.7.2. The main interest of the AT+KSLEEP=0 mode is to be able to forbid the sleep mode using the DTR signal.

- AT+KSLEEP=2  
In this mode the sleep state is never authorized what ever the DTR state.

A detailed description of those modes is given in [1].

### 3.7.2 Power supply and power consumption

The power supply input of VBAT ranges from 3.2V to 4.5V and 3.7V is nominal.

All measurements in communication mode are done at maximum RF power transmission (PCL max).

<sup>†</sup> Here we gives the logical state, '1' means connected to the ground

		-40°C	25°C		+85°C
		Typ.	Typ.	Max	Typ.
Off mode			35 µA	56 µA	
Stand-by mode DRX2 – connected to the network		1.4 mA	1.5 mA	1.7 mA	3.1 mA
Stand-by mode DRX5 – connected to the network		1.0 mA	1.0 mA	1.2 mA	2.5 mA
Stand-by mode DRX9 – connected to the network		0.8 mA	0.9 mA	1.1 mA	2.3 mA
CSD mode – in communication	GSM900 / GSM850		195 mA	220 mA	
	DCS / PCS		150 mA	170 mA	
GPRS when transmitting data (2 TX slots, 3 RX slots)	GSM900 / GSM850		360 mA		
	DCS / PCS		245 mA		
GPRS stand-by mode – 1 or 2 PDP context are open		The HiLo V2 behavior in GPRS stand-by mode is similar to GSM stand-by mode. The power consumption also depends on DRX and on other network setting (number of adjacent cells, etc.), it is between 1 and 3.4 mA.			
Current consumption during a burst <sup>‡</sup>	GSM900 / GSM850			1.7 A	
	DCS / PCS			1.3 A	

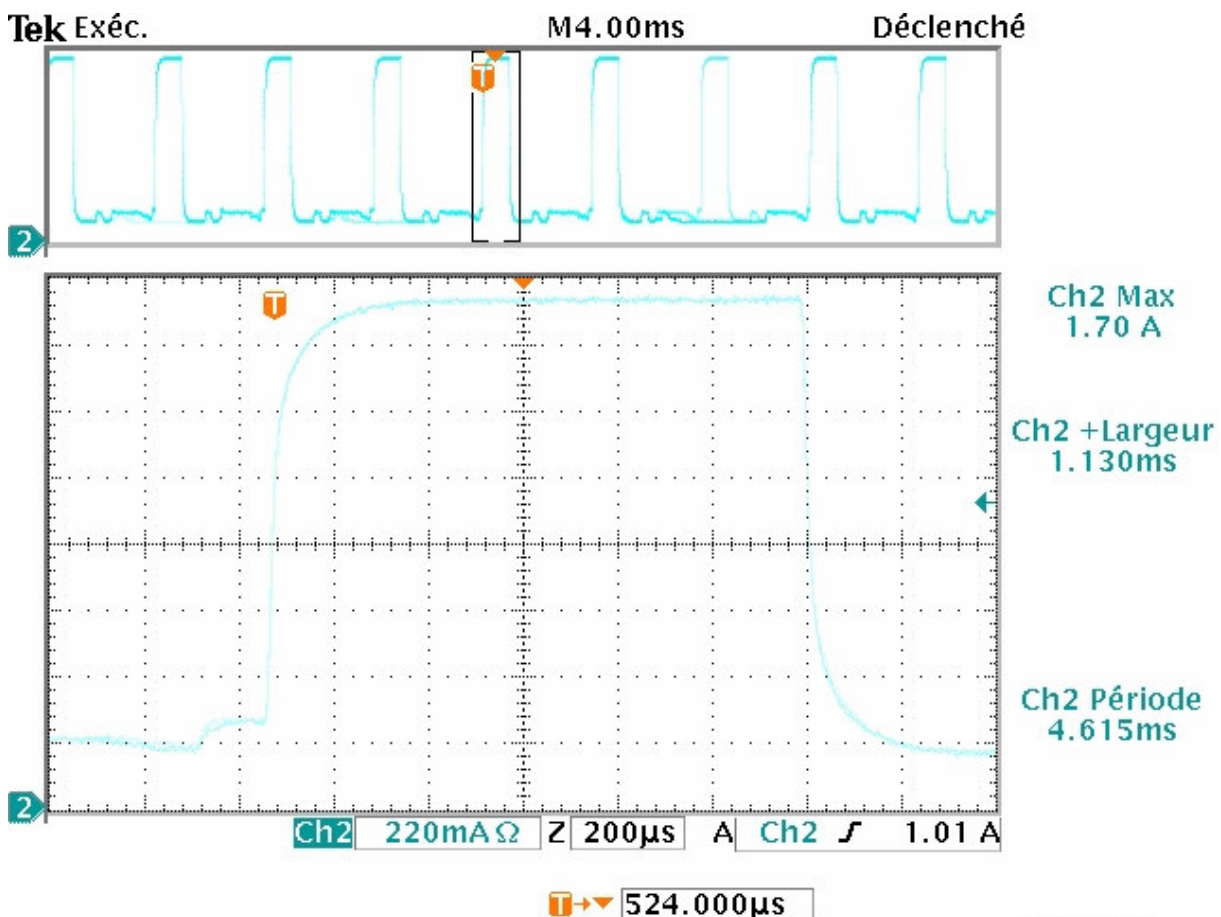
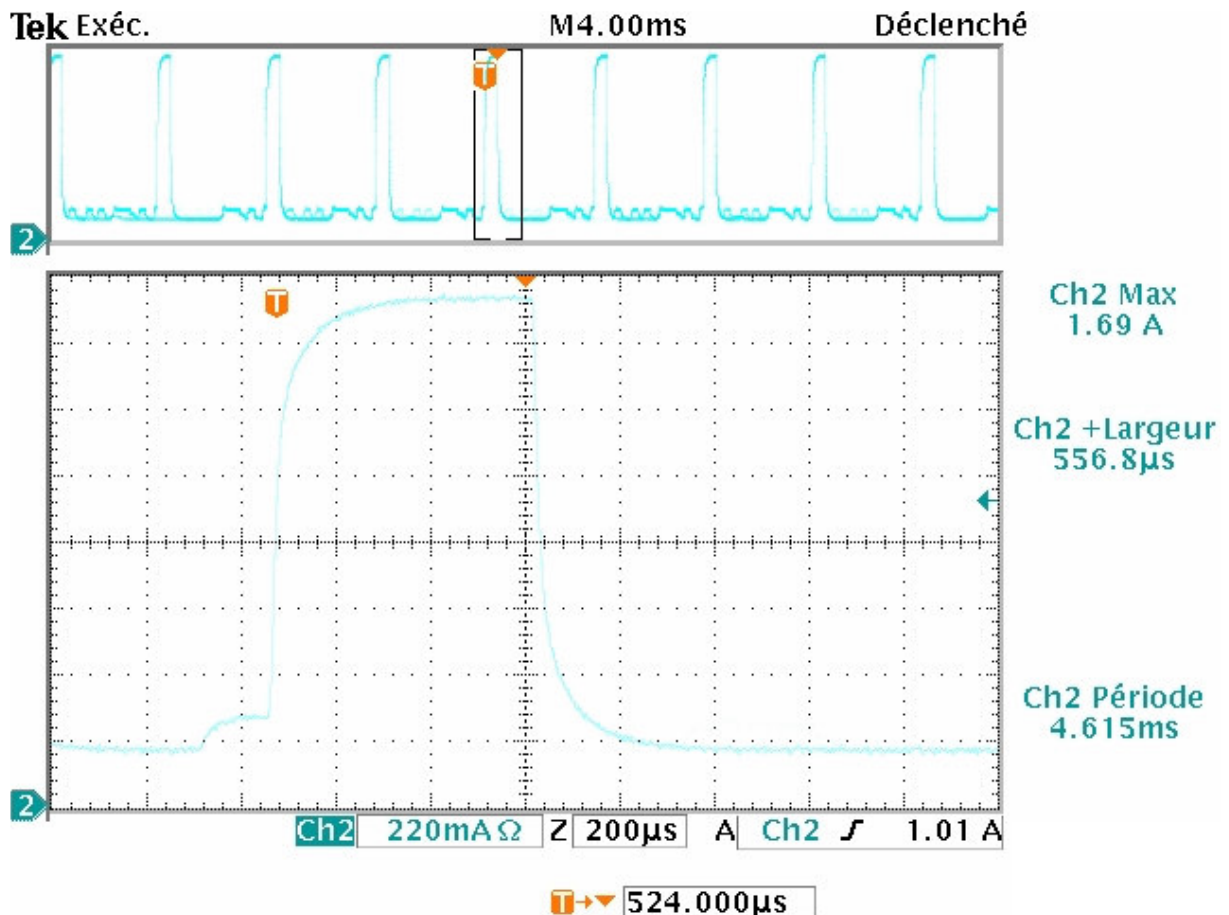

Figure 5: typical GPRS burst in the GSM900 frequency band

<sup>‡</sup> A burst transmission happens in Standby, communication and GPRS mode. This measurement is performed with a 680 µF capacitor on the power supply path required to remove the overshoot.



### 3.7.3 VGPIO

This +2.8V supply output is available on external pin of the module and can supply +2.8V external components. The current capability for 2.8V output is:

- 50mA in active mode
- 3mA in sleep mode.

### 3.7.4 VBACKUP

In order to keep the internal Real Time Clock available, a VBACKUP input is present on the module interface. Depending on the main battery voltage, the internal RTC is supplied by the VBACKUP or by the main power supply voltage:

RTC supply with external BACKUP present:

- If  $V_{BAT} < V_{BACKUP}$ , internal RTC is supplied by VBACKUP.
- If  $V_{BAT} \geq V_{BACKUP}$ , internal RTC is supplied by VBAT.

If no external Backup battery is used, VBACKUP input has to be connected to a 10 $\mu$ F capacitor (to ground).

An internal mechanism of the HiLo V2 module is able to manage the charge of the backup battery. More details about the battery choice and the charge schematics are given in the application note [2].

### 3.8 DATA / COMMAND MULTIPLEXING

The serial link between the DCE and a DTE (PDA, phone, etc) is used to send two different kinds of data flow: AT commands and PPP data packets. These two flows cannot be mixed together. So, this serial link can be used in two different exclusive modes:

- Command Mode: The serial link is reserved for the AT Commands flow
- Data Mode: The serial link is reserved for the data flow

But, during a data connection, the modem or the DTE may need to send some AT Commands to notify the other side of a major event. As there is just one serial link to send these two kinds of data, it is necessary to have a special procedure to switch from one kind to the other.

- The first solution provided by V25 ter is to use +++ and ATO. This solution, very simple to implement, has the main drawback to allow only the DTE to control the switch between the 2 modes and it is usually only used to hang up a data call.  
There is an option to this solution that can be activated using AT&D command. This option allows switching from data to command mode by toggling DTR from '1' to '0'.
- The second solution consists to implement the GSM 07.10 standard, this solution is available (customer has to develop its own driver for the host).  
Sagemcom recommends using this solution and provides driver source code for Linux platform.

## 4. PINOUT

### 4.1 I/O CONNECTOR PIN ASSIGNMENTS

Pin N°	Pin name	IO Type	Description
1	VBAT	Power supply input	+3.7 V power supply (nominal)
2	VBAT	Power supply input	+3.7 V power supply (nominal)
3	GND	Ground	GND
4	GND	Ground	GND
5	UART0_TXD	Digital output buffer	Trace UART0 transmit – Sagemcom use only
6	UART0_RXD	Digital input buffer	Trace UART0 receive – Sagemcom use only
7	RF_TX	Digital output buffer	RF power transmitting indicator
8	GPIO3	Digital bi-directional buffer	General purpose input/output 3
9	GPIO2	Digital bi-directional buffer	General purpose input/output 2
10	VGPIO	Power supply output	+2.8V power supply output
11	UART1_DSR	Digital output buffer	UART data set ready
12	UART1_DCD	Digital output buffer	UART data carrier detect
13	UART1_TXD	Digital output buffer	UART transmit
14	UART1_CTS	Digital output buffer	UART clear to send
15	SIM_RST	Digital output buffer	SIM reset
16	SIM_CLK	Digital output buffer	SIM clock
17	PWM0	Digital output buffer	DC PWM
18	RESET_IN	Digital input buffer	Module Reset input
19	AUX_ADC0	Analog input	Analog input to digital converter
20	INTMIC_P	Analog input	Differential input from microphone
21	HSET_OUT_P	Analog output	Differential output to earphone 32 ohms
22	HSET_OUT_N	Analog output	Differential output to earphone 32 ohms
23	PWM1	Digital output buffer	Buzzer PWM
24	VSIM	Power supply output	SIM power supply
25	SIM_DATA	Digital bi-directional buffer	SIM data
26	UART1_RXD	Digital input buffer	UART receive
27	UART1_RTS	Digital input buffer	UART request to send

28	UART1_RI	Digital output buffer	UART ring indicator
29	UART1_DTR	Digital input buffer	UART data terminal ready
30	VBACKUP	Power supply input/output	power supply for RTC backup
31	POK_IN	Digital input	Module power on signal
32	GPIO1	Digital bi-directional buffer	General purpose input/output 1
33	PCM_OUT	Digital output buffer	PCM data output
34	PCM_IN	Digital input buffer	PCM data input
35	PCM_SYNC	Digital bi-directional buffer	PCM sync signal
36	PCM_CLK	Digital bi-directional buffer	PCM clock signal
37	GND	Ground	GND
38	GND	Ground	GND
39	VBAT	Power supply input	+3.7V battery power supply (nominal)
40	VBAT	Power supply input	+3.7V battery power supply (nominal)

The signals which are unused must be left unconnected, except VBACKUP which must be connected to a 10 $\mu$ F capacitor (to ground). If flow control is not used on UART, the signal RTS must be connected to the signal CTS and the signal DTR must be connected to the signal DSR. For detailed information please refer to the HiLo V2 module Application Notes document.

Here is the Pinout delta between the HiLo and the HiLo V2:

HiLo	Pin Number	HiLo V2
SPI	5	UART0
	6	
	7	RF_TX
	35	PCM
	36	
GPIO3	33	
GPIO5	34	
GPIO4	8	GPIO3
Buzzer PWM2	18	RESET
DC PWM1	23	Buzzer PWM1

## 4.2 POWER DOMAINS AND UNUSED PINS POLICY

HiLo V2 Pins	Signal Name	Function	Power domain	Connection when not used / <b>Mandatory connected</b>
1	VBATT	POWER	3.7V	<b>VBATT</b>
2	VBATT	POWER	3.7V	<b>VBATT</b>
3	GND	POWER	0V	<b>0V</b>
4	GND	POWER	0V	<b>0V</b>
5	/UART0_TXD	UART 0	2.85V	Left Open
6	/UART0_RXD	UART 0	2.85V	Left Open
7	/RF_TX	RF	2.8V	Left Open
8	/GPIO3	GPIO	2.8V	Left Open
9	/GPIO2	GPIO	2.8V	Left Open
10	VGPIO	EXT_VDD	2.8V	Left Open
11	/UART1_DSR	UART 1	2.8V	Loop to DTR
12	/UART1_DCD	UART 1	2.8V	Left Open
13	/UART1_TXD	UART 1	2.85V	<b>TXD</b>
14	/UART1_CTS	UART 1	2.85V	Loop to RTS
15	/SIM_RST	SIM	1.8V or 2.9V	<b>SIM RESET</b>
16	/SIM_CLK	SIM	1.8V or 2.9V	<b>SIM CLOCK</b>
17	/PWM0	PWM	2.85V	Left Open
18	/RESET_IN	RESET	2.8V	Left Open
19	/AUX_ADC0	ADC	2.85V	Left Open
20	/INTMIC_P	AUDIO	2.85V	Left Open
21	/HSET_OUT_P	AUDIO	3.7V	Left Open
22	/HSET_OUT_N	AUDIO	3.7V	Left Open
23	/PWM1	PWM	2.85V	Left Open
24	VSIM	SIM	1.8V or 2.9V	<b>VSIM</b>
25	/SIM_DATA	SIM	1.8V or 2.9V	<b>SIM DATA</b>
26	/UART1_RXD	UART 1	2.85V	<b>RXD</b>
27	/UART1_RTS	UART 1	2.85V	Loop to CTS
28	/UART1_RI	UART 1	2.8V	Left Open
29	/UART1_DTR	UART 1	2.8V	Loop to DSR
30	VBACKUP	EXT_VDD	3.0V	C=10µF
31	/POK_IN	POWER ON	3.0V	<b>POWER ON</b>
32	/GPIO1	GPIO	2.8V	Left Open
33	/PCM_OUT	PCM	2.85V	Left Open
34	/PCM_IN	PCM	2.85V	Left Open
35	/PCM_SYNC	PCM	2.85V	Left Open
36	/PCM_CLK	PCM	2.85V	Left Open
37	GND	POWER	0V	<b>0V</b>
38	GND	POWER	0V	<b>0V</b>
39	VBATT	POWER	3.7V	<b>VBATT</b>
40	VBATT	POWER	3.7V	<b>VBATT</b>

## 5. ELECTRICAL SPECIFICATION

Five system operating states are defined:

- NO SUPPLY: No power voltage is present.
- BACKUP: Only backup battery is present.
- OFF: Main power voltage is present, backup voltage present or not.
- ACTIVE: Main power voltage is present, backup battery present or not. Internal power supplies are on.
- SLEEP: Main power voltage is present, backup battery present or not. Internal power supplies are in low power mode.

If not specified, all electrical values are given for the active state at VBAT=3.7V and an operating temperature of 25°C.

### 5.1 VBAT

The module is supplied through the VBAT signal with the following characteristics:

Parameter	Name	Min	Typ	Max
VBAT period (ms)	VbatTe (*)	4.614	4.615	DC
VBAT low duration (us)	VbatTi (*)	550	-	VBAT period
VBAT rise time (us)	VbatTr (*)	0	-	-
VBAT fall time (us)	VbatTf (*)	0	-	-
VBAT maximum voltage (V)	VbatMax (*)	-	-	4.5
VBAT minimum voltage (V)	VbatMin (*)	3.2	-	-
VBAT drop voltage (mV)	DeltaVbat (*)	-	-	300 (**)
Transient voltage (V)		2.9	-	-
Noise level (Vrms)@100KHz-1MHz		-	-	50mV

(\*): cf. Figure and Application Notes for more details.

(\*\*): This value depends on the power supply serial resistor (plus contact and tracks serial resistors)

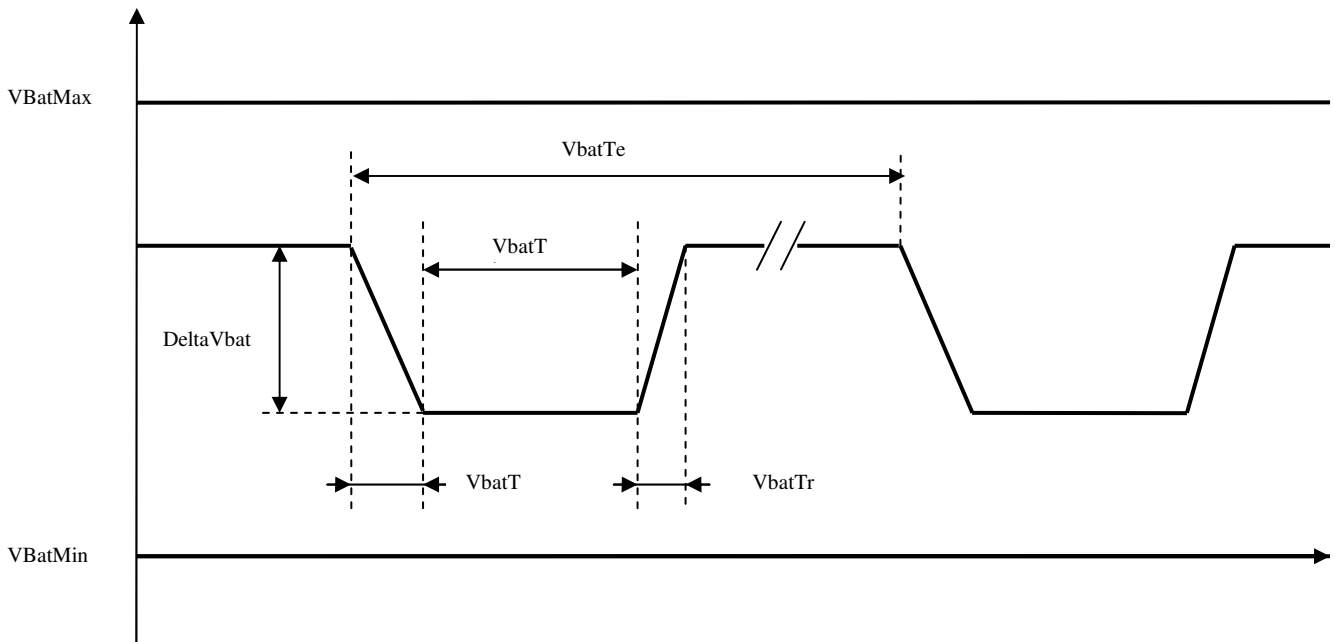

Figure 7: VBAT voltage waveform

## 5.2 VGPIO

Signal	Min	Typ	Max	Remarks
Voltage level(V)	2.65	2.80	2.95	Both active mode and sleep mode
Current capability active mode(mA)	-	-	50	
Current capability sleep mode(mA)	-	-	3	32KHz system clock enable
Line regulation(mV/V)	-	-	50	Iout = MAX
Rise Time(ns)	-	-	6	Test load capacitor = 30 pF

## 5.3 VBACKUP

Parameter	Min	Typ	Max	Remarks
Voltage level(V)		3		

## 5.4 VSIM

Parameter	Min	Typ	Max	Remarks
Output Voltage(V)	2.75	2.90	3.0	The appropriate output voltage is auto detected and selected by software
	1.65	1.80	1.95	
Output Current(mA)	-	-	10	In sleep mode Max output current = 3 mA
Line Regulation(mV/V)	-	-	50	IOUT = MAX
Powerup Setting Time(us) from Power down	-	10	-	

## 5.5 DIGITAL INTERFACE

The digital interface has the following characteristics, which includes UARTS, RF burst Indicator, Digital audio PCM, PWM, Reset and GPIOs.

Parameter	Min	Typ	Max	Remarks
Input Current-High( $\mu$ A)	-10	-	10	
Input Current-Low( $\mu$ A)	-10	-	10	
DC Output Current-High(mA) <sup>(1)</sup>	-	-	15	Pin driving a "1" with output set at "0"
DC Output Current-Low(mA) <sup>(1)</sup>	-15	-	-	Pin driving a "0" with output set at "1"
Input Voltage-High(V)	2.4			
Input Voltage-Low(V)	-	-	0.4	
Output Voltage-High(V)	2.7	-	-	
Output Voltage-Low(V)	-	-	0.1	

<sup>(1)</sup> The maximum current for one GPIO is 15mA, but all GPIOs can not provide 15mA at a time since the VIO is limited to 50mA

## 5.6 POK\_IN

The POK\_IN signal has the following characteristics:

Parameter	Min	Typ	Max
Input Voltage-Low(V)		-	0.4
Input Voltage-High(V)	2.4	-	3.3V
Powerup Period (ms) from POK_IN falling edge	2000	-	-



### 5.7 SIM

Signal	VL (V)		VH (V)	
	Min	Max	Min	Max
SIM_RST	Fully compliant to the GSM11.11 and ISO/IEC 7816-3 standards			
SIM_CLK				
SIM_DATA				

### 5.8 PWM

Two PWMs have the following characteristics

Signal	Frequency		Duty (%)		Remarks
	Min	Max	Min	Max	
PWM0 <sup>(1)</sup>	25.6KHz	1083.3KHz	0	100	

<sup>(1)</sup> General purpose PWMs with push pull output, an external transistor (NMOSFET) is required for driving buzzer, backlight...

The buzzer PWM has the following characteristics:

Signal	Frequency		Remarks
	Min	Max	
PWM1 <sup>(2)</sup>	243Hz	250KHz	

<sup>(2)</sup> PWM dedicated for driving buzzer.

It can't be used as a standard PWM. The average value is always 1.42V as it cannot be fixed to one specific level; this signal is always switching from high to low level.

## 5.9 AUX\_ADC

The Auxiliary ADC has the following characteristics. Detail description of the AT command is given in [1].

Parameter	Min	Typ	Max	Remarks
ADC Resolution(bits)	-	10	-	
Num of Inputs	-	-	1	AuxADC with Analog switch that supports 5 different selectable analog inputs
Input Voltage Range(V)	0	-	1	1 general purpose input
	0	-	3	1 general purpose input in div-by-3 mode
	0	-	5.5	battery voltage input
	4.2	-	5.5	battery voltage input (zoom)
Update rate per channel(kHz)	-	-	200	Depends on the number of channels engaged. 200 kHz assumes one channel actively sampling.
Differential Nonlinearity(bits)	-1	-	+3	
Integral Nonlinearity(bits)	-2.5	-	+2.5	
Offset Error(mV)	-	5	-	
Gain Error(mV/LSB)	-	0.02	-	
Input Resistance (k $\Omega$ )	120	-	-	Typical Rin is 150 k $\Omega$ for DIV3 mode, 300 k $\Omega$ for battery measure mode (normal mode), 270 k $\Omega$ for zoom mode, and capacitive-only for normal mode.
Input Capacitance (pF)	-	-	10	

## 5.10 UART1

TXD, RXD, CTS, RTS, DCD, DSR, DTR and RI have the following characteristics:

Signal	VL (V)		VH (V)	
	Min	Max	Min	Max
UART1_TX		0.1	2.7	3.2
UART1_RX		0.4	2.4	3.2
UART1_RTS		0.4	2.4	3.2
UART1_CTS		0.1	2.7	3.2
UART1_DCD		0.1	2.7	3.2
UART1_DTR		0.4	2.4	3.2
UART1_DSR		0.1	2.7	3.2
UART1_RI		0.1	2.7	3.2



## 5.11 AUDIO SIGNALS

### 5.11.1 Audio Inputs

The audio inputs contain the following characteristics:

Parameter	Min	Typ	Max	Test Conditions
Maximum input range		1.4V		With Gain = - 6dB
Nominal reference level		16mV		Typical value Gain = + 34dB
Input Micro amplified gain (dB)	-6		+ 50	

### 5.11.2 Audio Outputs

The audio outputs contain the following characteristics:

Parameter	Min	Typ	Max	Test Conditions
Maximum output range		1.65 V <sub>eff</sub>		Load=32Ω, THD=1%, Output gain = 8 dB
Load resistance (Ω)		32		
Output amplifier gain (dB)	-28	-	8	

## 5.12 RF SIGNALS

### 5.12.1 Load mismatch

The module accept a VSWR < 20:1 (all phase angles) without damage or permanent degradation  
The module accept a VSWR < 12:1 (all phase angles) without any spurious emission > - 30 dBm

### 5.12.2 Input VSWR

The typical input VSWR is 1.5:1 (max = 1.5:1)

### 5.12.3 Antenna matching network

A matching network in HiLo is optimized for 50 ohm work load.

To get good performance in application, an additional matching circuit and adjustment for actual antenna is required. A π-type matching network is recommended in HiLo application note [2].



## 6. ENVIRONMENTAL SPECIFICATION

Parameter	Min	Max
Ambient temperature Normal range	-20 °C	+80 °C
Ambient temperature Extended range	-40 °C	+85 °C
Storage temperature	-40 °C	+85 °C
Long damp heat Operating conditions	Tested at +60 °C, 95% during 504 hours	
Short damp heat Storage and transportation conditions	Tested at +40 °C, 95% RH during 96 hours	

### 6.1 NORMAL TEMPERATURE RANGE

ETSI performances are guaranteed by Sagemcom in the range of -20 °C to +80 °C.

Enhanced sensitivity performance at 25 °C is guaranteed as follow:

Frequency band	GSM850	EGSM	ETSI value
Min sensitivity (dBm) for BER = 2.4%	-108	-108	< -102

Frequency band	DCS	PCS	ETSI value
Min sensitivity (dBm) for BER = 2.4%	-107	-107	< -102

### 6.2 EXTENDED TEMPERATURE RANGE

#### 6.2.1 Sensitivity

Frequency band	GSM850		EGSM		ETSI value
Temperature (°C)	-40	+85	-40	+85	
Typical sensitivity (dBm)	-109	-107	-109	-107	< -102

Frequency band	DCS		PCS		ETSI value
Temperature (°C)	-40	+85	-40	+85	
Typical sensitivity (dBm)	-108	-106	-108	-106	< -102



### 6.2.2 Transmission characteristics

Typical transmission values obtained at extreme temperature

Frequency band	GSM850		EGSM		ETSI value	
	-40	+85	-40	+85	min	max
Temperature (°C)	-40	+85	-40	+85	min	max
Output power - max. PCL (dBm)	31.8	31.9	31.8	31.7	30.5	35.5
Frequency error (Hz)	50	41	46	37	- 90	+ 90
Phase error RMS (degree)	2.6	2.4	2.6	2.3	-	5°

Frequency band	DCS		PCS		ETSI value	
	-40	+85	-40	+85	min	max
Temperature (°C)	-40	+85	-40	+85	min	max
Output power - max. PCL (dBm)	29.1	28.8	28.7	28.7	27.5	30.5
Frequency error (Hz)	65	66	69	66	-180	180
Phase error RMS (degree)	2.6	2.3	2.4	2.4	-	5°

### 6.2.3 Power consumption

See §3.7.2

### 6.3 OUT OF OPERATIONAL RANGE

No operation is guaranteed by Sagemcom out of the extended range. However, it has been observed on several modules:

Temperature range	Comments
-50°C to -40°C and +85°C to 125°C	HiLo V2 modules keeps the communication without any anomaly
125°C to 150°C	No permanent damage is observed but some modules reboot themselves
T = 150°C	The flash memory may be erased and the module has to be retrofited
T < -50°C and T > 150°C	No test has been performed



## **7. ESD**

Using human body model from JEDEC JESD 22-A114 standard, the HiLo V2 can stand for +/-2kV ESD on all pins of the 40 points connector and on the RF connector.

## 8. MECHANICAL SPECIFICATION

### 8.1 PHYSICAL DIMENSIONS

Whole size: 27 x 27 x 3.6

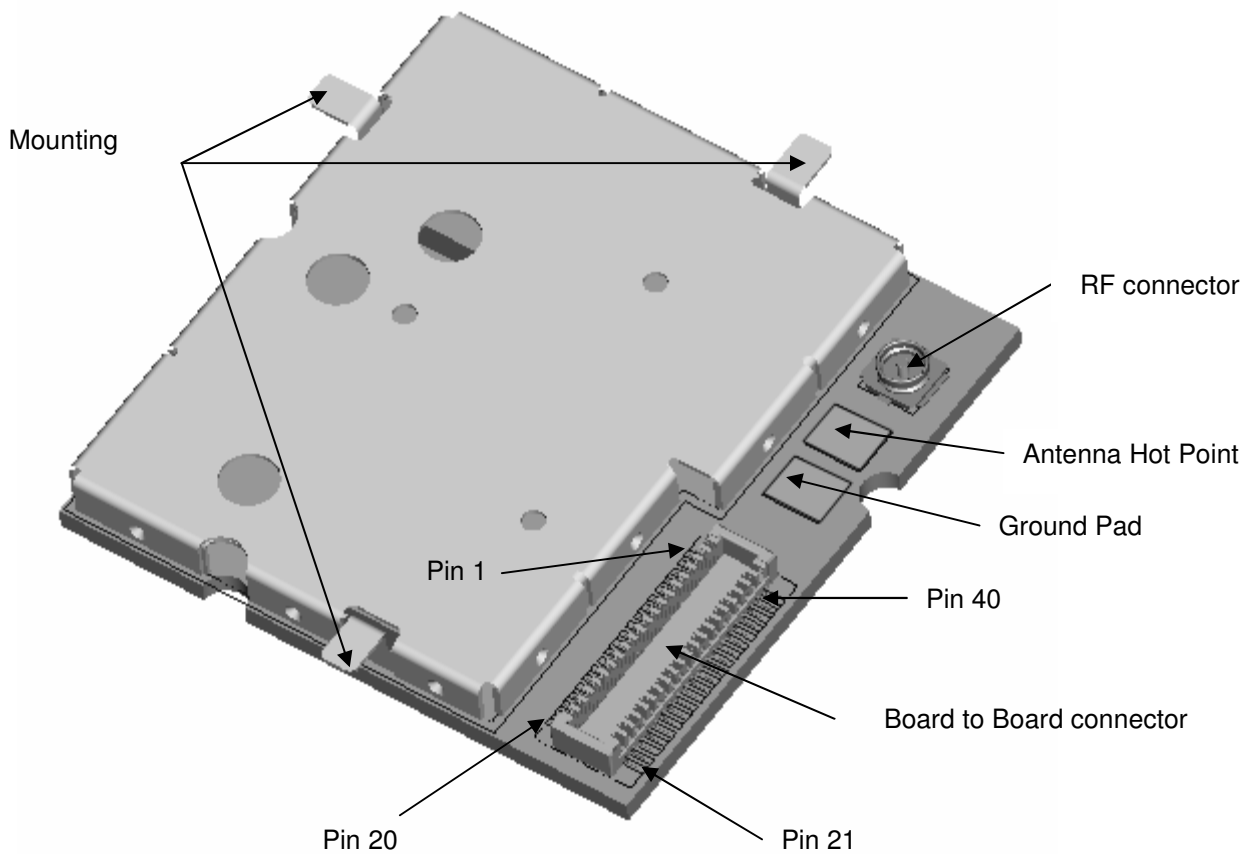

Figure 8: HiLo V2 interface

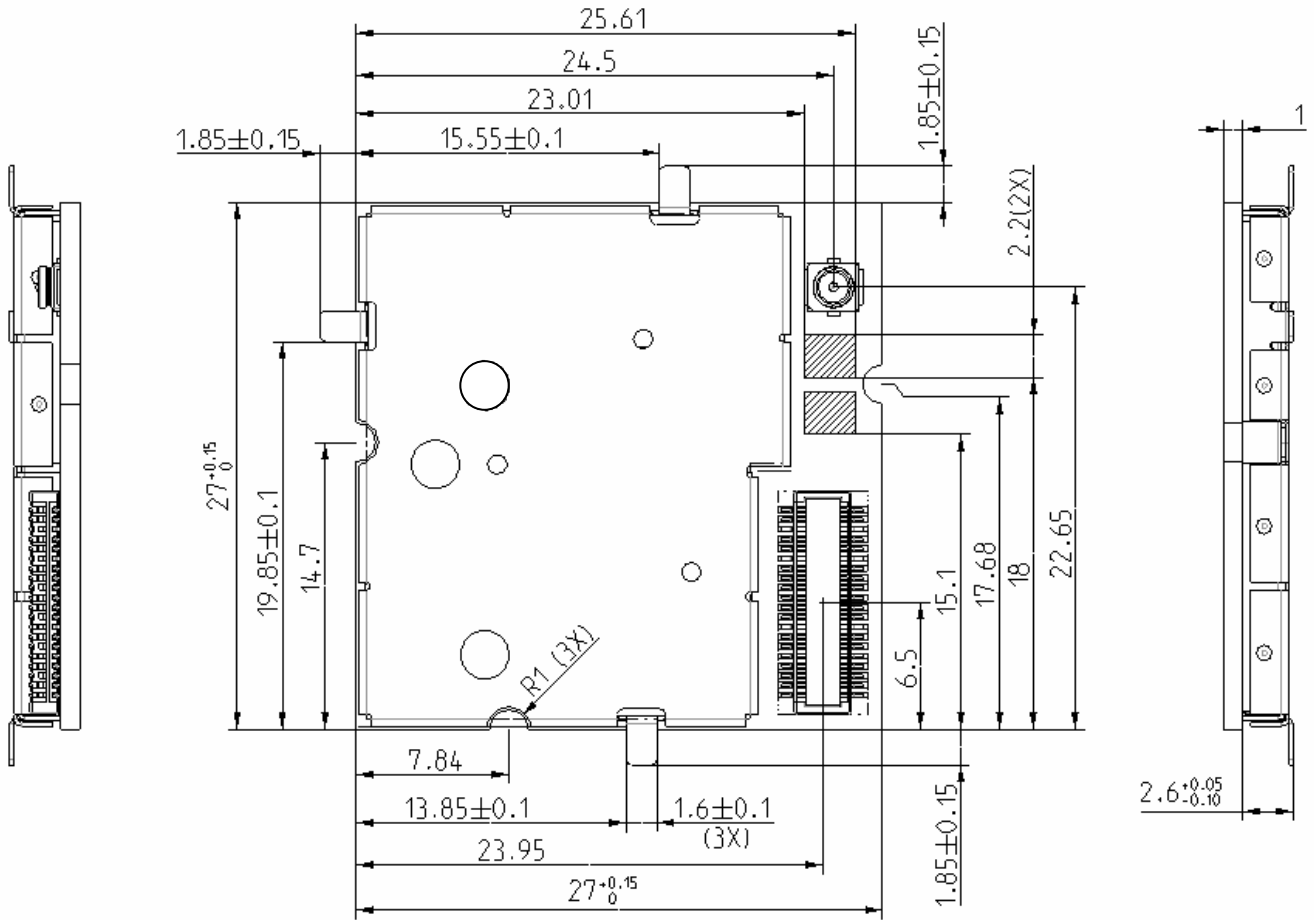

Figure 9: HILO V2 dimensions

## 8.2 ASSEMBLY

Shield frame is soldered on HiLo V2 PCB; Shield cover is assembled with shield frame and removable.

The recommended solution to fix the HiLo V2 module is to manually solder the three mounting pins (represented on Figure 8 and Figure 10) on the motherboard.

The solder pad geometries for the mounting pins are given in Figure 5. The assembly description of the module under the mother board is described on Figure 5 and Figure 6.

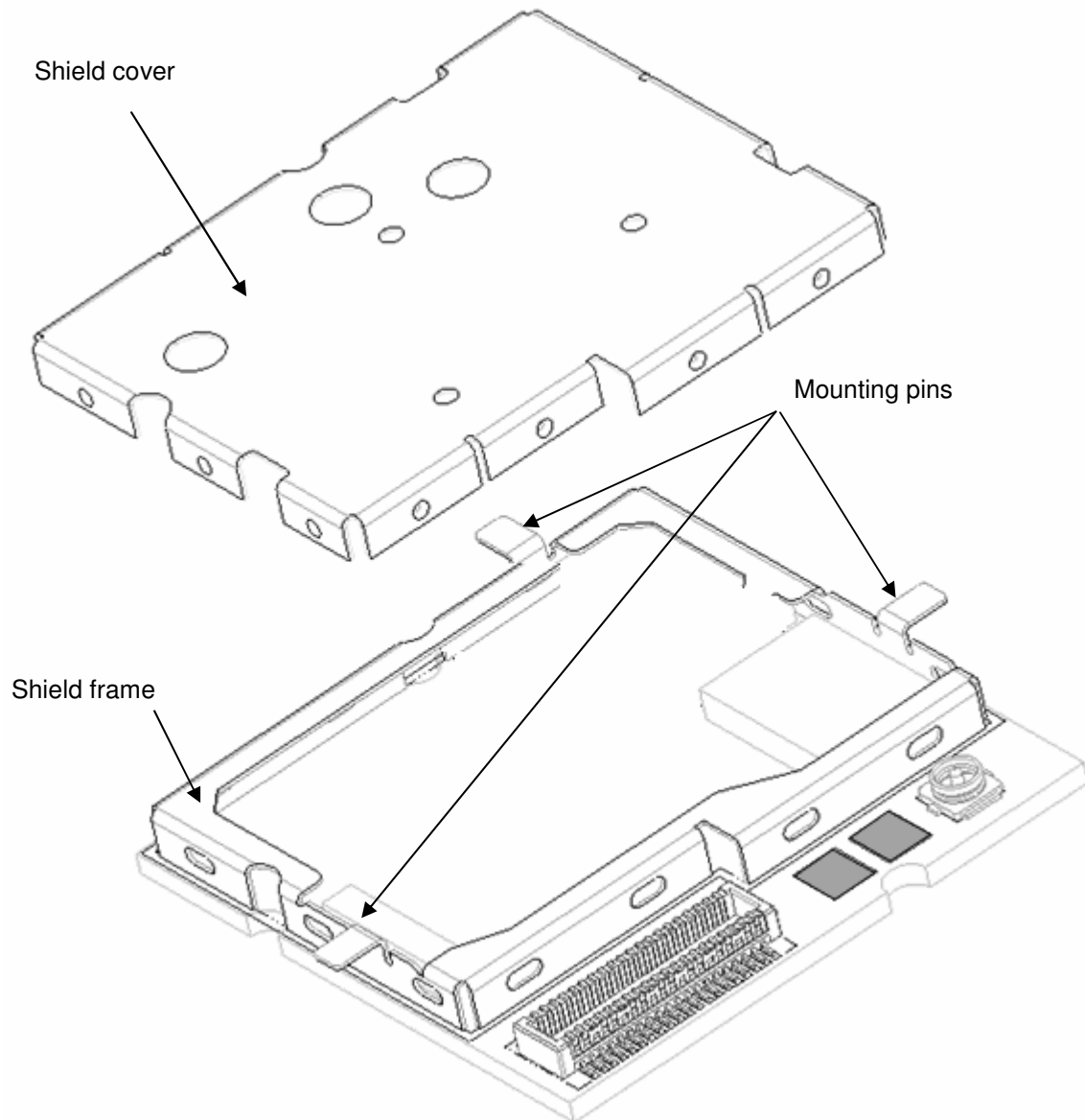

Figure 10: HiLo V2 decomposition

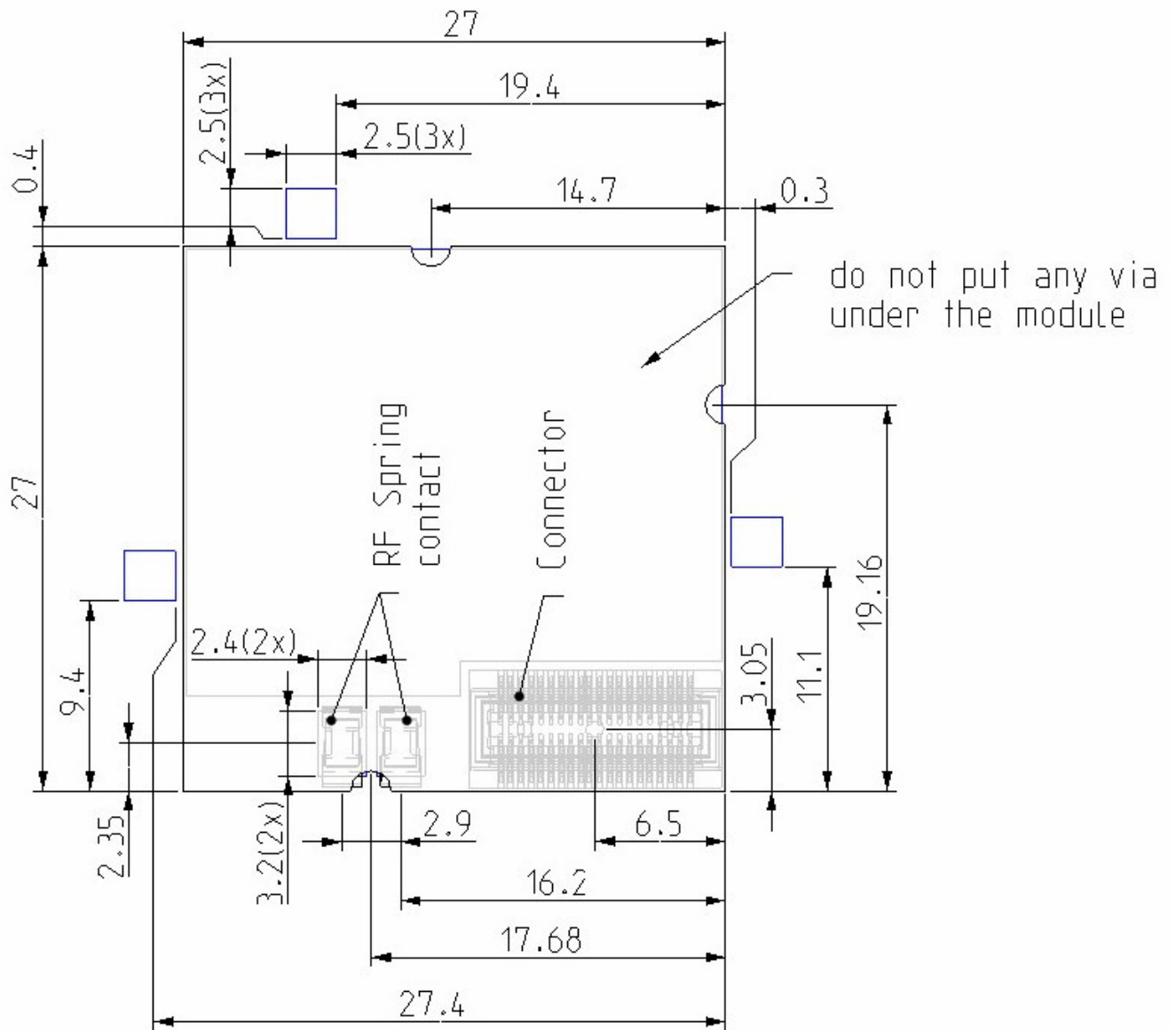

Figure 5: HiLo V2 Assembly Geometry on mother board

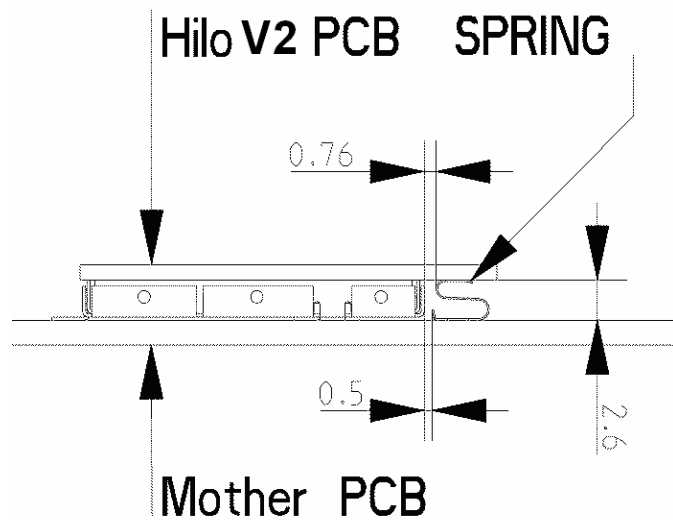

Figure 6: Spring contact assembly

### 8.3 TERMINAL ASSIGNMENTS

#### 8.3.1 Board to Board connection

A pair of 40-pin-connector connects HiLo V2 and DTE.

##### 8.3.1.1 HiLo V2 connector

Dimensions and references:

Pins Number	Reference
40	MOLEX 53885-0401

Dimension	A	B	C
mm	11.45	9.5	10.55

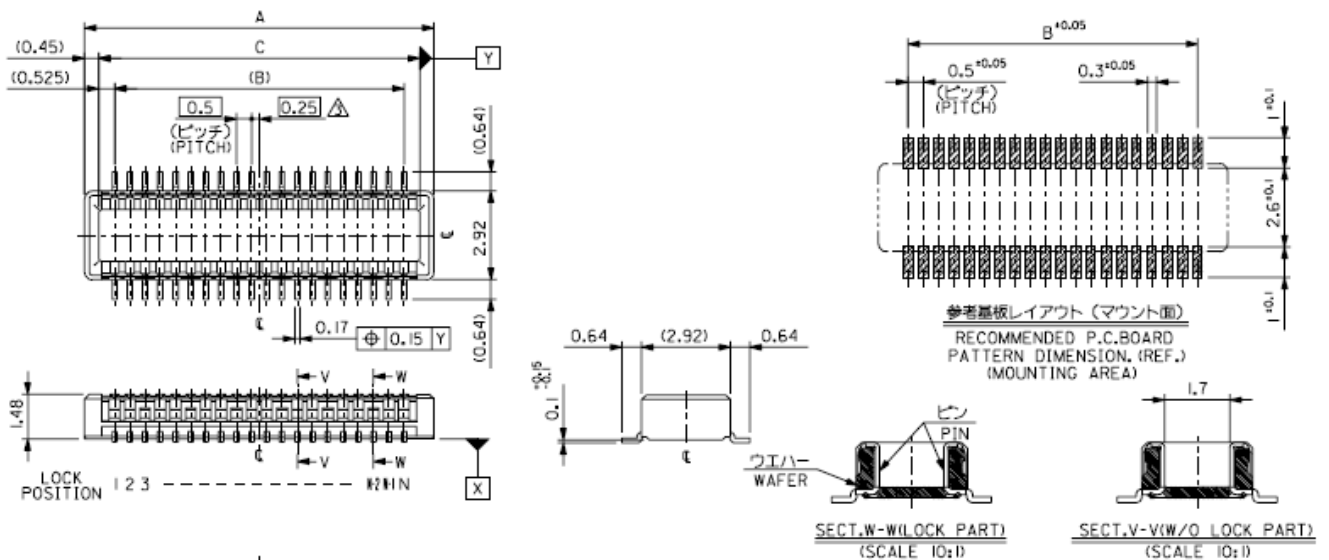

Figure 7: HiLo V2 connector drawing

### 8.3.1.2 Mother board connector

Dimensions and references:

Pin Number	References
40	MOLEX 54102-0403

Dimension	A	B	C
mm	12.6	9.5	10.5

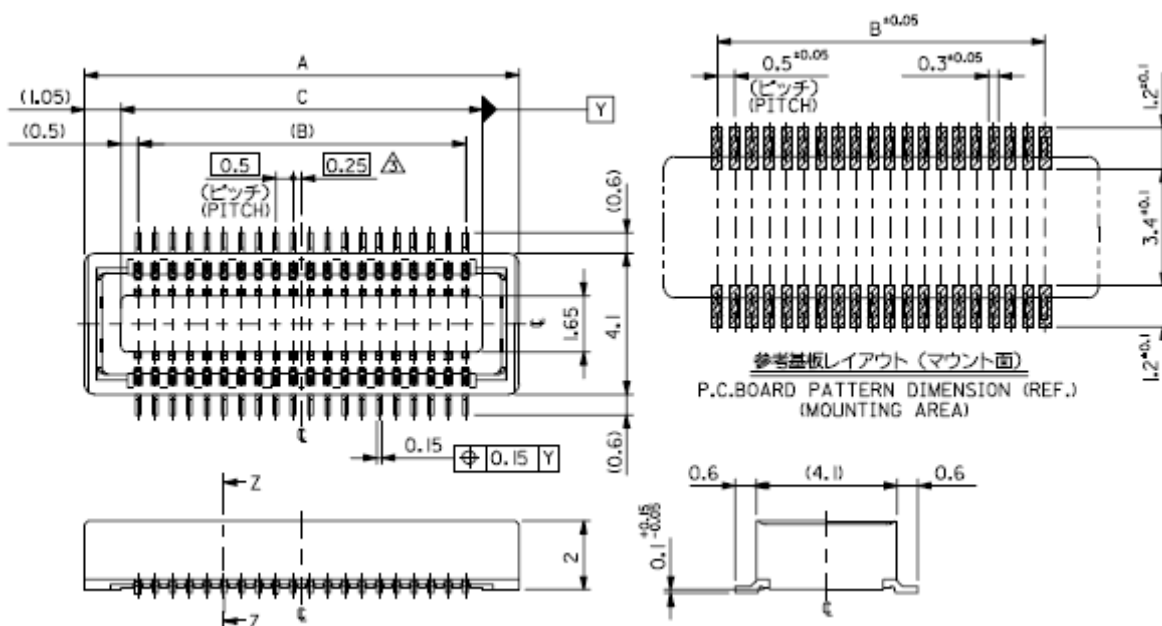

Figure 8: Mother board connector drawing

### 8.3.2 Antenna connection

Two kinds of antenna connection are for client's selection.

#### 8.3.2.1 Antenna pad

A pair of copper pad on the HiLo V2 PCB could be used for antenna connection with RF spring

#### 8.3.2.2 Antenna connector

A 50-Ohm RF connector on the HiLo V2 PCB is available for antenna (RF cable) connection.

Reference
HIROSE U.FL-R-SMT-1 (10)





## **9. ORDERING AND CONTACT INFORMATION**

### **9.1 PART NUMBERS**

Module :

253358736      MODULE HILO V2 SP QBM

This reference includes the most recent software and generic parameters

Connector :

189880290      CONN.40C.F.DRT.CMS P=0,5 HCC=2,5(HILO)SP

### **9.2 CONTACT**

Email : [wireless-modules@sagem.com](mailto:wireless-modules@sagem.com)

Web : <http://www.sagemcom.com/>

SAGEMCOM,  
Wireless M2M Modules  
250, route de l'empereur  
92848 Rueil-Malmaison Cedex  
FRANCE



## **10. REFERENCE DOCUMENTS**

- [1] URD1 OTL 5635.1 008 70248 - AT Command Set for SAGEMCOM Hilo HiloNC Modules
- [2] URD1 OTL 5635.2 007 72335 Ed1 - HiLo V2 application note
- [3] Getting started – How to manage DTR

# SAGEMCOM

All rights reserved. The information and specifications included are subject to change without prior notice. Sagemcom tries to ensure that all information in this document is correct, but does not accept liability for error or omission. Non contractual document.. All trademarks are registered by their respective owners.

## **Sagemcom Energy & Telecom SAS**

Siège social : 250, route de l'Empereur - 92848 RUEIL-MALMAISON CEDEX - FRANCE  
Tél : +33(0)1 57 61 10 00 - Fax : +33 (0)1 57 61 10 01  
S.A.S. au capital de 44 824 840 € - 518 250 337 RCS Nanterre  
[www.sagemcom.com](http://www.sagemcom.com)