

HILONC V2 TECHNICAL SPECIFICATION



~ Freedom of speech
for smart machines ~

SAGEMCOM

NOTE D'ETUDE / TECHNICAL DOCUMENT**FICHE RECAPITULATIVE / SUMMARY SHEET**

Ed	Date <i>Date</i>	Référence <i>Reference</i>	Pages modifiées <i>/ Changed</i> pages	Observations <i>Comments</i>
1	13/01/2010	URD1- OTL 5665.3-001 / 71927		Creation du document / <i>Document creation</i>
2	08/02/2010	URD1- OTL 5665.3-001 / 71927	6, 7, 10, 19, 25, 27, 28, 34.	Minor corrections.
3	08/02/2010	URD1- OTL 5665.3-001 / 71927	13, 14, 15, 19, 20, 21	Pad out modification in the PCM Bus, Trace UART0 and RF_TX burst indicator.
4	04/03/2010	URD1- OTL 5665.3-001 / 71927	8,9, 13,14,15, 29,30, 34	Add STK feature; Update Pad out, Logic level of RF_TX and correct AT*PSCPOF; Update standard requirement on receiving sensitivity; Update shield can drawing.
5	17/03/2010	URD1- OTL 5665.3-001 / 71927	36	MSL level and DRAFT watermark removed.
6	03/03/2011	URD1- OTL 5665.3-001 / 71927	6,7,8,16, 29,31,36, 37	Update directive and standard list, power consumption, environmental specification, MTBF, ordering and contact information, reference documents

SOMMAIRE / CONTENTS

1. INTRODUCTION	5
1.1 PRODUCT CONCEPT	5
1.2 STANDARDS	5
1.3 TERMS AND ABBREVIATION	6
1.4 CONVENTIONS	7
1.5 PRODUCT FEATURES OVERVIEW	7
2. BLOCK DIAGRAM	9
3. FUNCTIONAL DESCRIPTION	10
3.1 SIM	10
3.1.1 SIM card interface	10
3.1.2 SIM card connection	10
3.2 AUDIO	11
3.2.1 Analog Audio	11
3.2.2 Digital Audio.....	11
3.3 PWM	12
3.4 DATA	12
3.4.1 Data services.....	12
3.4.2 UART: V24.....	12
3.4.3 UART2 (trace interface).....	13
3.5 SPARE I/O	13
3.6 RF BURST INDICATOR	14
3.7 POWER MANAGEMENT	14
3.7.1 SLEEP MODES	14
3.7.2 Power supply and power consumption	15
3.7.3 VGPIO.....	17
3.7.4 VBACKUP	17
3.8 DATA / COMMAND MULTIPLEXING	17
4. PADOUT	18
4.1 POWER DOMAINS AND UNUSED PADS POLICY	20
5. ELECTRICAL SPECIFICATION	22
5.1 VBAT	22
5.2 VGPIO	23
5.3 VBACKUP	23
5.4 VSIM	24
5.5 DIGITAL INTERFACE	24
5.6 POK_IN	24
5.7 RESET.....	25
5.8 SIM	25
5.9 PWM	25
5.10 AUX_ADC.....	26
5.11 UART1.....	26
5.12 ANALOG AUDIO SIGNALS	27

5.12.1	Analog Audio Inputs	27
5.12.2	Analog Audio Outputs	27
5.13	RF SIGNALS	27
5.13.1	Load mismatch	27
5.13.2	Input VSWR	27
5.13.3	Antenna matching network	27
6.	ENVIRONMENTAL SPECIFICATION	28
6.1	NORMAL TEMPERATURE RANGE	28
6.1.1	Sensitivity	28
6.1.2	Power consumption	28
6.2	OUT OF OPERATIONAL RANGE	28
7.	ESD	29
8.	MTBF	30
8.1	RESULTS	30
8.2	AUTOMOTIVE PROFILE (PRODUCT IN PASSENGER COMPARTMENT)	30
8.3	TELECOM PROFILE (GROUND NON STATIONARY SEVERE)	30
9.	MECHANICAL SPECIFICATION	31
9.1	DESCRIPTION	31
9.2	PHYSICAL DIMENSIONS	32
9.3	DECOMPOSITION	33
10.	CUSTOMER PROCESS	34
10.1	FOOTPRINT	34
10.2	PACKAGING	35
10.3	MSL	35
10.4	SOLDER PROCESS	35
10.5	UNDERFILL	35
11.	ORDERING AND CONTACT INFORMATION	36
11.1	PART NUMBER	36
11.2	CONTACT	36
12.	REFERENCE DOCUMENTS	37

1. INTRODUCTION

This document describes the hardware interface of the Sagemcom HiLoNC V2 module that connects to the cellular device application and the air interface. This new HiLoNC V2 offers new features compare to HiLoNC which are Digital audio link and RF burst indicator.

1.1 PRODUCT CONCEPT

The HiLoNC V2 module is one of the smallest available GPRS (multislot class 10) quad band module of the market with SMT compatible pads. The target application is the Machine to Machine (M2M) market including automotive, AMM (Automatic Metering Management), tracking system, Alarm, etc. Despite its small size and cost, it has comprehensive GSM/GPRS services, data and IP features.

In addition to its size it has the following outstanding characteristics:

- Automotive temperature range: -40 °C to +85 °C
- Minimum low power consumption in idle mode: 1.25 mA in DRX5
- Full automotive qualification regarding ISO16750 standards
- High input voltage range: 3.2 V to 4.5 V
- Digital PCM audio
- Fully form factor compliant with the HiLoNC
- Pad to pad compliant with the main HiLoNC pads (power supplies, UART, Sim and reset lines)

As other Sagemcom GSM/GPRS/EDGE modules, it has a full set of AT commands as well as analog audio interface [1].

In addition to the HiLoNC V2 module a complete development kit can be provided to customers.

1.2 STANDARDS

This product with its evaluation board has been approved to comply with the directives and standards listed below:

Directives

99/05/EC	« Directive of the European Parliament and of the council of 9 March 1999 on radio equipment and telecommunications terminal equipment and the mutual recognition of their conformity », in short referred to as R&TTE Directive 1999/5/EC
2004/108/EC	Directive on electromagnetic compatibility
2006/95/EC	« Directive on electrical equipment designed for use within certain voltage limits » (Low Voltage Directive)
2002/95/EC 95/94/EC	RoHS Directive Automotive EMC Directive
FCC part 2 FCC part 15 FCC part 22 FCC part 24	Frequency allocations and radio treaty matters Radio frequency devices subpart B – Unintentional Radiators Public mobile services subpart H – Cellular Radio Telephone Service Personal Communications Services, PCS (Narrow band PCS 901-902, 930-931, 940-941 MHz. Broadband PCS 1850-1990 MHz)
IC RSS 132, issue 2	Cellular Telephones Employing New Technologies Operating in the Bands 824-849 MHz and 869-894 MHz
IC RSS 133, issue 5	2 GHz Personal Communications Services
ACMA AS/ACIF	Requirements for connection to an air interface of a Telecommunications Network - Part

S042.1 1: General
 ACMA AS/ACIF Requirements for connection to an air interface of a Telecommunications Network - Part
 S042.3 3: GSM Customer Equipment

Standards of type approval

3GPP TS 51.010-1 Digital cellular telecommunications system (Phase 2); Mobile Station (MS) conformance specification

ETSI EN 301 511 Candidate Harmonized European Standard (Telecommunications series) Global System for Mobile communications (GSM); Harmonized standard for mobile stations in the GSM 900 and DCS 1800 bands covering essential requirements under article 3.2 of the R&TTE directive (1999/5/EC) (GSM 13.11 version 7.0.1 Release 1998)

ETSI EN 301 489-1
 V1.8.1 Electromagnetic compatibility and Radio spectrum Matters (ERM); ElectroMagnetic Compatibility (EMC) standard for radio equipment and services; Part 1: Common technical requirements

ETSI EN 301 489-7
 V1.3.1 Candidate Harmonized European Standard (Telecommunications series) Electro Magnetic Compatibility and Radio spectrum Matters (ERM); Electro Magnetic Compatibility (EMC) standard for radio equipment and services; Part 7: Specific conditions for mobile and portable radio and ancillary equipment of digital cellular radio telecommunications systems (GSM and DCS)

EN 62 311 : 2008 Assessment of electronic and electrical equipment related to human exposure restrictions for electromagnetic fields (0 Hz - 300 GHz)

EN60950-1: 2006
 +A11 2009 Safety of information technology equipment

GCF-CC ver 3.39.0 Global Certification Forum - Certification Criteria

PTCRB ver 5.4 PCS Type Certification Review Board

Requirements of quality

IEC 60068 Environmental testing

AEC – Q100 Automotive Electronic Council Q100 – Stress Qualification For Integrated Circuits. AEC – Q100 is used as a guide line to qualify the HiLoNC V2 module.

1.3 TERMS AND ABBREVIATION

ADC Analog to Digital Converter
 CODEC Coder-Decoder
 CTS Clear To Send
 DCS Digital Communications System
 DSR Data Set Ready
 DTR Data Terminal Ready
 EGSM Enhanced GSM
 ESD Electrostatic Discharge
 ETS European Telecommunication Standard
 GSM Global System for Mobile communication
 GPRS General Packet Radio Services
 IC Integrated Circuit
 IEEE Institute of Electrical and Electronics Engineers
 I/O Input / Output
 ISO International Standards Organization
 ITU International Telecommunication Union
 JTAG Joint Test Action Group
 Kbps kilobit per second
 LCD Liquid Crystal Display

LED	Light Emitting Diode
Mbps	Megabit per second
PBCCH	Packet Broadcast Channel
PCB	Printed Circuit Board
PCS	Personal Communication System
PCM	Pulse Code Modulation
PWM	Pulse Width Modulation
RAM	Random Access Memory
RF	Radio Frequency
RI	Ring Indication
RMS	Root Mean Square
RTS	Ready To Send
RX	Reception
SIM	Subscriber Identification Module
SMS	Short Message Service
SMT	Surface Mount Technology
STK	SIM Tool Kit
TBC	To Be Confirmed
TBD	To Be Defined
TX	Transmission
UART	Universal Asynchronous Receiver and Transmitter
USSD	Unstructured Supplementary Service Data

1.4 CONVENTIONS

Throughout this document, DTE (Data Terminal equipment) indicates the equipment which masters and controls the module device HiLoNC V2 by sending AT commands via its serial interface.

DCE (Data Communication Equipment) indicates the module device HiLoNC V2.

1.5 PRODUCT FEATURES OVERVIEW

Temperature range	Normal range: -20°C to +80°C (fully compliant) Extended range: -40°C to -20°C and +80°C to +85°C (fully functional) Storage: -40°C to +85°C
Weight (in g)	< 3g
MSL	Level 3
ESD	ESD protection < 2 kV
Physical dimensions	24x24x2.5 mm (typical)
Connection	51 pads around the module, compatible with SMT process
Power supply	3.2V to 4.5V range, 3.7V nominal
Power consumption	Off mode: 35 μ A typical Typical Stand-by mode: - 1 mA in DRX5 Communication mode (at Pmax): - 220 mA for GSM/850 - 170 mA for DCS/PCS
Battery charge management and interface	No battery charge management is included.
Antenna	No antenna is included in the module.

* The power consumption is highly dependent on customer's product design and environment of GSM Module

Frequency bands	Sagemcom module supports GSM850, EGSM900, DCS1800, PCS 1900
Voice codec	Half Rate, Full Rate, Enhanced Full Rate, Adaptive Multi Rate
GSM class	Small MS
Transmit power	Class 4 (2W) for GSM850 / EGSM900 Class 1 (1W) for DCS1800 / PCS1900
Supported SIM card	3V and 1.8V SIM cards
SIM slot	Signals for the management of the SIM card are provided on the 51 pads
PWM	Signals for LED, vibrating device and Buzzer management are provided on the PWM interface
Audio up-link	1 single end input is provided for microphone
Audio down-link	1 differential output is provided for non stereo earphone
Audio PCM	4 lines for the digital audio bus
UART interface with flow control	Up to 115.2 Kbps with auto-bauding. Full flow control signals (+2.8V) are provided on 51 pads. A reference schematic to build the RS232 interface is provided in the HiLoNC V2 application note.
UART trace interface	Up to 115.2Kbps trace RX-TX UART (Only for Sagemcom use)
Data/command multiplexing	Software management of data/command multiplexing on the serial link UART
Data services	GPRS, CSD, Fax
Supplementary services (supported via AT commands)	Caller Line Identification, Call Waiting, Call Hold, Call Forwarding, Multiparty, Call Barring, Advice of Charge, STK, USSD, CPHS
Power on pad	Available, low level active
Reset pad	Available, low level active
General purpose I/Os pad	3 GPIO + 1 ADC available
RF Transmit Indicator	1 IO indicating the RF power amplifier activity, high level active.
GSM release	R99
GPRS	SMG 31bis, Multi slot class 10, class B terminal, PBCCH support
GSM/DCS certification GCF-CC	V3.29.0
PCS certification	NAPRD03 (V3.13.0)

2. BLOCK DIAGRAM

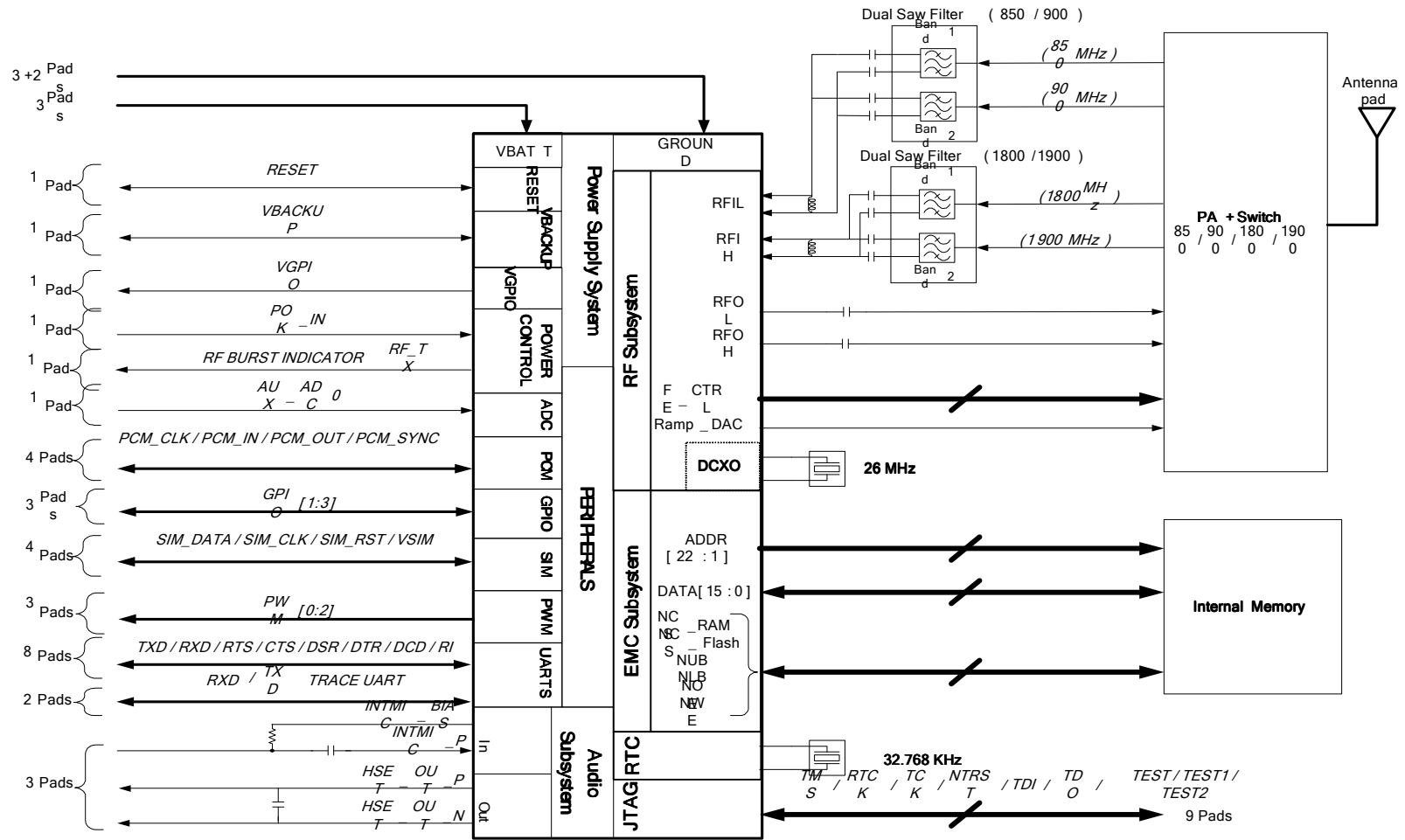

Figure 1: HiLoNC V2 block diagram

3. FUNCTIONAL DESCRIPTION

3.1 SIM

3.1.1 SIM card interface

The SIM card interface is compatible with the ISO 7816-3 IC card standard on the issues required by the GSM 11.11 Phase 2+ standard and adapts to 3V and 1.8V SIM card.

To prevent SIM card's damages, the power supply of the module has to be turned off before any manipulation on SIM card.

The SIM card interface includes:

- Power supply output (VSIM)
- Bi-direction data signal (SIM_DATA),
- Clock output (SIM_CLK)
- Reset signal (SIM_RST)

Signal	Pad N°	Description
SIM_RST	45	SIM reset, provided by Base-band processor
SIM_CLK	44	SIM clock, provided by Base-band processor
VSIM	47	SIM supply voltage
SIM_DATA	46	SIM serial data line, input and output

3.1.2 SIM card connection



Figure 2: SIM connection

3.2 AUDIO

3.2.1 Analog Audio

The module supports the following voice codec:

- Half-Rate
- Full-Rate
- Enhanced Full Rate
- Adaptive Multi Rate

Signal	Pad N°	Description
INTMIC_P	1	Single end input signal for microphone
HSET_OUT_P	50	Positive polarized output signal for external speaker
HSET_OUT_N	51	Negative polarized output signal for external speaker

It manages an external microphone (INTMIC_P) in single end mode and an external earphone (32 Ohms HSET_OUT_P/HSET_OUT_N) in differential mode.

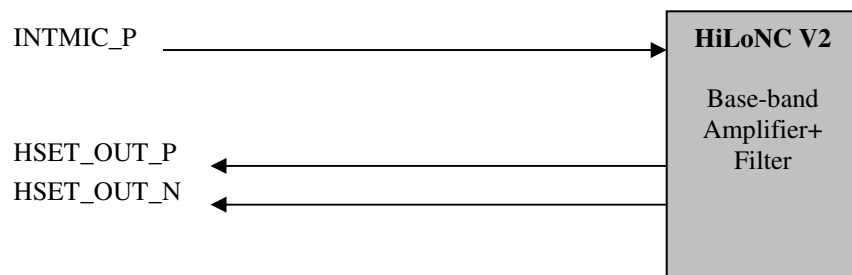

Figure 3: Audio

To ensure proper operation of such sensitive signal, the audio signals should be isolated by ground on DTE layout. Characteristics of microphone, speaker and reference schematic are given in the application notes.

3.2.2 Digital Audio

The HiLoNC V2 M2M module features a PCM interface.

The PCM interface is a High speed full duplex interface that can be used to send and receive digital audio data to external audio ICs.

PCM interface features include the following:

- PCM master mode
- Full duplex operation
- 16 bits PCM data word length
- Configurable PCM clock rate up to 1MHz

Signal	Pad N°	Description
PCM_IN	20	PCM data input
PCM_OUT	19	PCM data output
PCM_SYNC	18	PCM sync signal
PCM_CLK	17	PCM clock signal

3.3 PWM

Three PWM interfaces are available on the module. Two are general purpose PWM which can be used for driving a vibrating device, keypad backlight or LED. The third one is dedicated to drive a buzzer. All the PWMs can be controlled through AT commands, allowing several periods and duty cycles. More details are given in the AT commands specification.

Signal	Pad N°	Description
PWM0	6	DC PWM 0
PWM1	43	DC PWM 1
PWM2	42	Buzzer PWM

3.4 DATA

3.4.1 Data services

The module supports the following services:

- Built-in data / fax Modem
- Data over CSD:
 - 9.6 kbps
 - Non transparent mode only
 - V.32 or V.110
- Data over GPRS:
 - 2 PDP contexts at the same time
 - Internal IP stack : 8 sockets can be opened at the same time. But only 1 FTP socket can be open at the same time. *E.g.: 1 FTP socket , 1 FTP server and 6 TCP/UDP connections.*

3.4.2 UART: V24

A V24 interface is provided on external pads of the module with the following signals:

- RX/TX
- RTS/CTS
- DSR
- DTR
- DCD
- RI

It supports auto bauding mode and the baud rate up to 115.2 Kbps.

Signal	Pad N°	Description
UART_DSR	33	UART Data Set Ready
UART_DCD	34	UART Data Carrier Detect
UART_TX	39	UART Transmit
UART_RTS	37	UART Request To Send
UART_RX	38	UART Receive
UART_CTS	40	UART Clear To Send
UART_RI	35	UART Ring Indicator
UART_DTR	36	UART Data Terminal Ready

3.4.3 UART2 (trace interface)

A two lines UART interface is provided on external pads of the module with the following signals:

- UART0_TXD
- UART0_RXD

This interface is reserved for Sagemcom traces, it can not be used for other purpose, it is strongly recommended to leave this interface accessible on 2 tests points on the Customers PCB.

Signal	Pad N°	Description
UART0_TXD	32	Trace interface UART transmit
UART0_RXD	25	Trace interface UART receive

3.5 SPARE I/O

There are 3 GPIO that can be customized easily from the customer's application through appropriate AT commands. They can be configured as input or output.

Signal	Pad N°	Description
GPIO1	15	General Purpose Input/Output 1
GPIO2	14	General Purpose Input/Output 2
GPIO3	26	General Purpose Input/Output 3

3.6 RF BURST INDICATOR

One digital output signal on the 2.8V domain is available to indicate the RF transmissions. It is high level active and can therefore be connected to a transistor and a LED to give a visual indication of the RF activity.

Signal	Pad N°	Description
RF_TX	16	RF power transmitting indicator

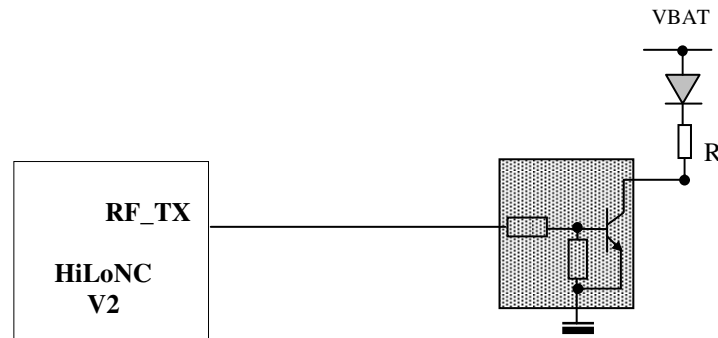

Figure 4: RF TX burst indicator

3.7 POWER MANAGEMENT

3.7.1 SLEEP MODES

Two kinds of sleep mode are available:

- The “off mode”,
- The “stand-by” mode.

They are described below.

3.7.1.1 Off mode

When the module is in off mode it can not receive any call, it can not receive any AT commands but can be awoken either by its internal clock using AT+CALA [1] or using POK_IN signal [2]. To go to this mode use AT*PSCPOF.

3.7.1.2 Stand-by mode management

There are three stand-by modes management:

- **AT+KSLEEP=0**
In this mode the sleep state is controlled by the DTR and by the firmware
 - DTR = 1[†] - The module never goes to sleep mode
 - DTR = 0 - The module goes to sleep mode when it is ready and **can not** be awoken with an AT command. To wake up the module the user must toggle DTR to 1.
 Remark: even in this mode it is possible to use DTR signal to go from data to command mode, however in this case DTR has to be toggled from 1 to 0 then from 0 to 1 (see §3.8)
- **AT+KSLEEP=1**
In this mode the sleep state is only controlled by the firmware.
The module goes to sleep mode when it is ready. The module may be awoken with any character received on the UART. However to be sure to wake up the module the "0x00" character has to be sent.

In both previous modes the power consumption in sleep mode is given in §3.7.2. The main interest of the AT+KSLEEP=0 mode is to be able to forbid the sleep mode using the DTR signal.

- **AT+KSLEEP=2**
In this mode the sleep state is never authorized what ever the DTR state.

A detailed description of those modes is given in [3].

3.7.2 Power supply and power consumption

The power supply input of VBAT ranges from 3.2V to 4.5V and 3.7V is nominal.

All measurements in communication mode are done at maximum power emissions.

		-40°C	25°C		+85°C
		Typ.	Typ.	Max	Typ.
Off mode			35 µA	56 µA	
Stand-by mode DRX2 – connected to the network		1.4 mA	1.5 mA	1.7 mA	3.1 mA
Stand-by mode DRX5 – connected to the network		1.0 mA	1.0 mA	1.2 mA	2.5 mA
Stand-by mode DRX9 – connected to the network		0.8 mA	0.9 mA	1.1 mA	2.3 mA
CSD mode – in communication	GSM900 / GSM850		195 mA	220 mA	
	DCS / PCS		150 mA	170 mA	
GPRS when transmitting data (2 TX slots, 3 RX slots)	GSM900 / GSM850		360 mA		
	DCS / PCS		245 mA		
GPRS stand-by mode – 1 or 2 PDP context are open		The HiLoNC V2 behavior in GPRS stand-by mode is similar to GSM stand-by mode. The power consumption also depends on DRX and on other network setting (number of adjacent cells, etc.), it is between 1 and 3.4 mA.			
Current consumption during a burst [‡]	GSM900 / GSM850			1.7 A	
	DCS / PCS			1.3 A	

[†] "1" is the logical state, 'then means connected to the ground

[‡] A burst transmission happens in Standby, communication and GPRS mode. This measurement is performed with a 680 µF capacitor on the power supply path required to remove the overshoot.

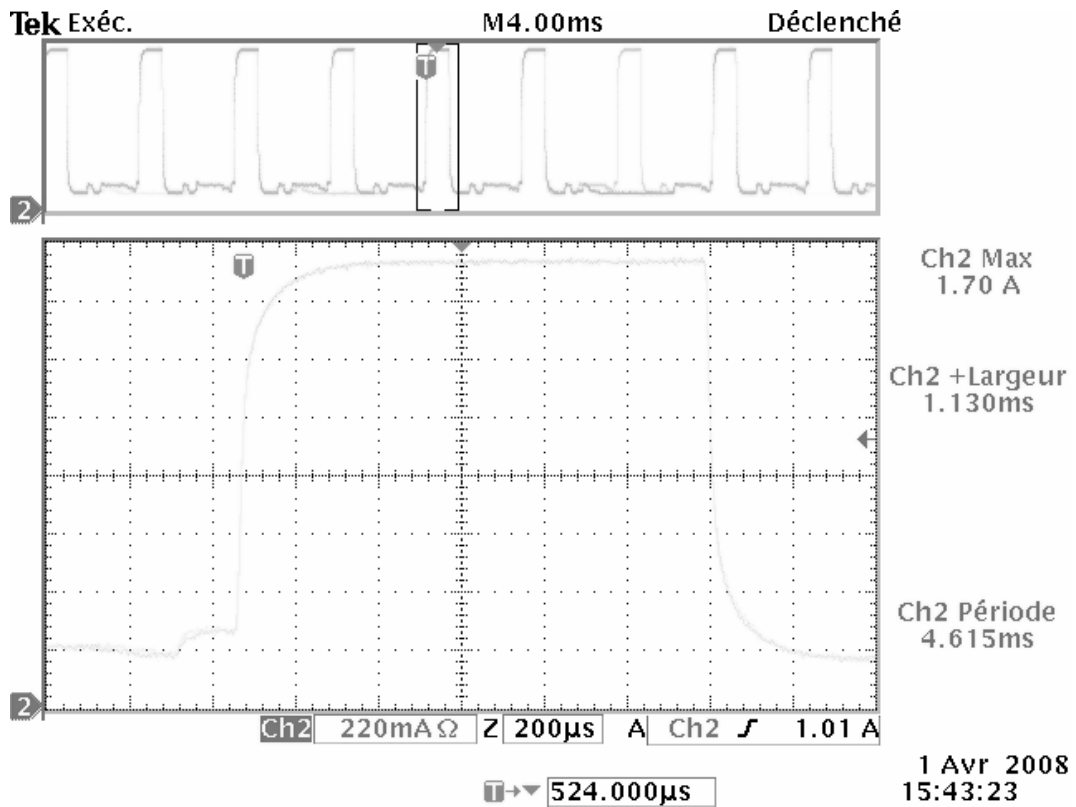

Figure 5: typical GPRS burst in the GSM900 frequency band

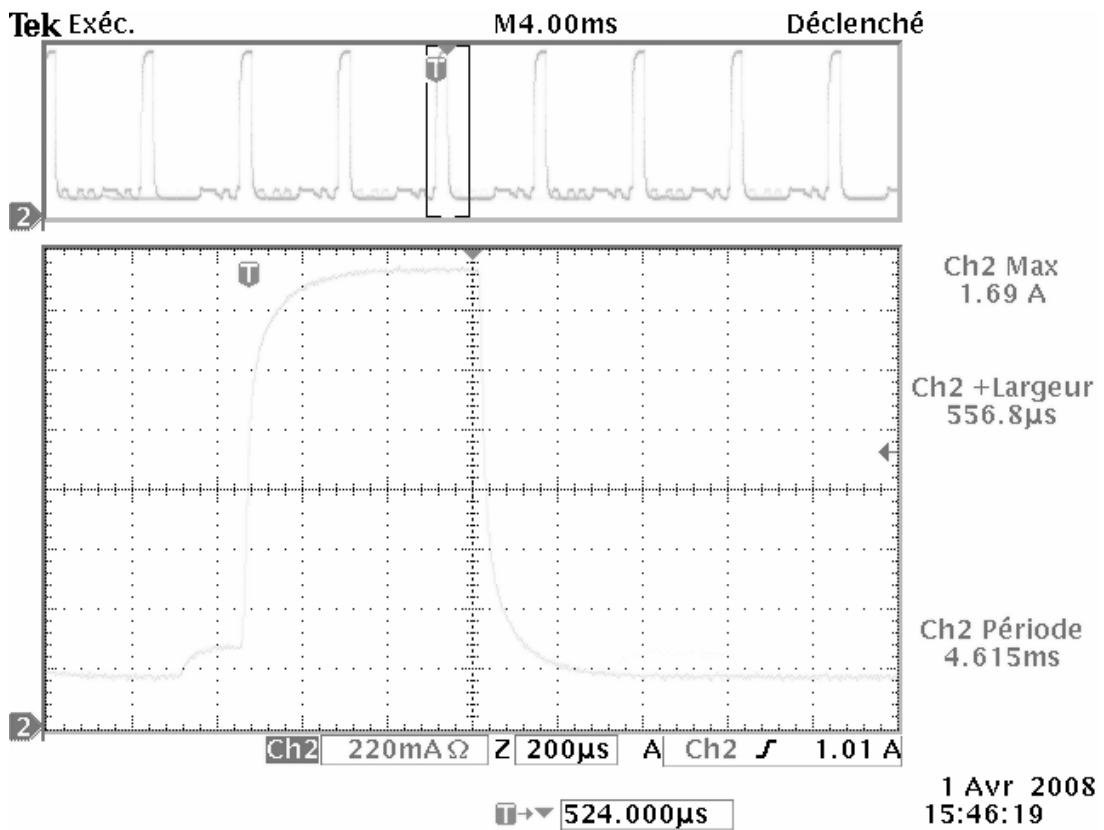

Figure 6: typical GSM burst in the GSM900 frequency band

3.7.3 VGPIO

This +2.8V supply output is available on external pin of the module and can supply +2.8V external components. The current capability for 2.8V output is:

- 50mA in active mode
- 3mA in sleep mode

3.7.4 VBACKUP

In order to keep the internal Real Time Clock available, the VBACKUP input is present on the module interface. Depending on the main battery voltage, the internal RTC is supplied by the VBACKUP or by the main power supply voltage:

RTC supply with external BACKUP present:

- If $V_{BAT} < V_{BACKUP}$, internal RTC is supplied by VBACKUP.
- If $V_{BAT} \geq V_{BACKUP}$, internal RTC is supplied by VBAT.

If no external Backup battery is used, VBACKUP input has to be connected to a 10 μ F capacitor (to ground) .

An internal mechanism of the HiLoNC V2 module is able to manage the charge of the backup battery. More details about the battery choice and the charge schematics are given in the application note [2].

3.8 DATA / COMMAND MULTIPLEXING

The serial link between the DCE and a DTE (PDA, phone, etc) is used to send two different kinds of data flow: AT commands and PPP data packets. These two flows cannot be mixed together. So, this serial link can be used in two different exclusive modes:

- Command Mode : the serial link is reserved for the AT Commands flow
- Data Mode : the serial link is reserved for the data flow

But, during a data connection, the modem or the DTE may need to send some AT Commands to notify the other side of a major event. As there is just one serial link to send these two kinds of data, it is necessary to have a special procedure to switch from one kind to the other.

- The first solution provided by V25 ter is to use +++ and ATO. This solution very simple to implement, has the main drawback to allow only the DTE to control the switch between the 2 modes and it is usually only used to hang up a data call.
There is an option to this solution that can be activated using AT&D command. This option allows switching from data to command mode by toggling DTR from '1' to '0'.
- The second solution consists to implement the GSM 07.10 standard, this solution is available (customer has to develop its own driver for the host).
Sagemcom recommends using this solution and provides driver source code for Linux platform.

4. PADOUT

Pad N°	Pad name	IO Type	Description
1	INTMIC_P	Analog input	Single ended input from microphone
2	AUX_ADC0	Analog input	Analog input to digital converter
3	GND	Ground	GND
4	VGPIO	Power supply output	+2.8V power supply output
5	VBACKUP	Power supply input/output	Power supply for RTC backup
6	PWM0	Digital output buffer	DC PWM 0
7	RESET	Digital input buffer	Module Reset
8	TDI	Digital input buffer	JTAG purpose
9	TDO	Digital output buffer	JTAG purpose
10	TMS	Digital bi-directional buffer	JTAG purpose
11	TRST	Digital bi-directional buffer	JTAG purpose
12	TCK	Digital bi-directional buffer	JTAG purpose
13	RTCK	Digital bi-directional buffer	JTAG purpose
14	GPIO2	Digital bi-directional buffer	General purpose input/output 2
15	GPIO1	Digital bi-directional buffer	General purpose input/output 1
16	RF_TX	Digital output buffer	RF power transmitting indicator
17	PCM_CLK	Digital bi-directional buffer	PCM clock signal
18	PCM_SYNC	Digital bi-directional buffer	PCM sync signal
19	PCM_OUT	Digital output buffer	PCM data output
20	PCM_IN	Digital input buffer	PCM data input
21	GND	Ground	GND
22	JTAG1	Digital bi-directional buffer	JTAG configuration
23	JTAG2	Digital bi-directional buffer	JTAG configuration
24	TEST	Digital bi-directional buffer	JTAG configuration
25	UART0_RXD	Digital input buffer	Trace UART0 receive
26	GPIO3	Digital bi-directional buffer	General purpose input/output 3
27	GND_RF	Ground	RF Ground
28	RF	Antenna	RF signal
29	GND_RF	Ground	RF Ground
30	VBAT	Power supply input	+3.7 V power supply (nominal)
31	VBAT	Power supply input	+3.7 V power supply (nominal)
32	UART0_TXD	Digital output buffer	Trace UART0 transmit
33	UART1_DSR	Digital output buffer	UART1 data set ready
34	UART1_DCD	Digital output buffer	UART1 data carrier detect
35	UART1_RI	Digital output buffer	UART1 ring indicator
36	UART1_DTR	Digital input buffer	UART1 data terminal ready
37	UART1_RTS	Digital input buffer	UART1 request to send

38	UART1_RX	Digital input buffer	UART1 receive
39	UART1_TX	Digital output buffer	UART1 transmit
40	UART1_CTS	Digital output buffer	UART1 clear to send
41	POK_IN	Digital input	Module power on signal
42	PWM2	Digital output buffer	Buzzer PWM
43	PWM1	Digital output buffer	DC PWM 1
44	SIM_CLK	Digital output buffer	SIM clock
45	SIM_RST	Digital output buffer	SIM reset
46	SIM_DATA	Digital bi-directional buffer	SIM data
47	VSIM	Power supply output	SIM power supply
48	VBAT	Power supply input	+3.7V battery power supply (nominal)
49	GND	Ground	GND
50	HSET_OUT_P	Analog output	Differential output to earphone 32 ohms
51	HSET_OUT_N	Analog output	Differential output to earphone 32 ohms

The signals which are unused must be left unconnected, except VBACKUP which must be connected to a 10 μ F capacitor (to ground). If flow control is not used on UART, the signal RTS must be connected to the signal CTS and the signal DTR must be connected to the signal DSR. For detailed information please refer to the HiLoNC V2 module Application Notes document.

Here is the Padout delta between the HiLoNC and the HiLoNC V2:

HiLoNC	Pad Number	HiLoNC V2
SPI	16	RF_TX
	17	PCM
	18	
	19	
	20	
GPIO5	32	UART0
GPIO4	25	

4.1 POWER DOMAINS AND UNUSED PADS POLICY

HiLoNC V2 Pads	Signal Name	Function	Power domain	Connection when not used / Mandatory connected
E1	/INTMIC_P	AUDIO	2.85V	Left Open
E2	/AUX_ADC0	ADC	2.85V	Left Open
E3	GND	POWER	0V	0V
E4	VGPIO	EXT_VDD	2.8V	Left Open
E5	VBACKUP	EXT_VDD	3.0V	C=10µF
E6	/PWM0	PWM	2.85V	Left Open
E7	/RESET_IN	RESET	2.8V	Left Open
E8	/JTAG_TDI	JTAG	2.8V	Left Open
E9	/JTAG_TDO	JTAG	2.8V	Left Open
E10	/JTAG_TMS	JTAG	2.8V	Left Open
E11	/JTAG_TRST	JTAG	2.8V	Left Open
E12	/JTAG_TCK	JTAG	2.8V	Left Open
E13	/JTAG_RTCK	JTAG	2.8V	Left Open
E14	/GPIO2	GPIO	2.8V	Left Open
E15	/GPIO1	GPIO	2.8V	Left Open
E16	/RF_TX	RF	2.8V	Left Open
E17	/PCM_CLK	PCM	2.85V	Left Open
E18	/PCM_SYNC	PCM	2.85V	Left Open
E19	/PCM_OUT	PCM	2.85V	Left Open
E20	/PCM_IN	PCM	2.85V	Left Open
E21	GND	POWER	0V	0V
E22	/JTAG1	JTAG	2.8V	Left Open
E23	/JTAG2	JTAG	2.8V	Left Open
E24	/TEST	JTAG	2.8V	Left Open
E25	/UART0_RXD	UART 0	2.85V	Left Open
E26	/GPIO3	GPIO	2.8V	Left Open
E27	GND	RF	0V	0V
E28	/ANTENNA	RF	3.7V	ANTENNA
E29	GND	RF	0V	0V
E30	VBATT	POWER	3.7V	VBATT
E31	VBATT	POWER	3.7V	VBATT
E32	/UART0_TXD	UART 0	2.85V	Left Open
E33	/UART1_DSR	UART 1	2.8V	Loop to DTR
E34	/UART1_DCD	UART 1	2.8V	Left Open
E35	/UART1_RI	UART 1	2.8V	Left Open
E36	/UART1_DTR	UART 1	2.8V	Loop to DSR
E37	/UART1_RTS	UART 1	2.85V	Loop to CTS
E38	/UART1_RX	UART 1	2.85V	RXD
E39	/UART1_TX	UART 1	2.85V	TXD

HiLoNC V2 Pads	Signal Name	Function	Power domain	Connection when not used / Mandatory connected
E40	/UART1_CTS	UART 1	2.85V	Loop to RTS
E41	/POK_IN	POWER ON	3.0V	POWER ON
E42	/PWM2	PWM	2.85V	Left Open
E43	/PWM1	PWM	2.85V	Left Open
E44	/SIM_CLK	SIM	1.8V or 2.9V	SIM CLOCK
E45	/SIM_RST	SIM	1.8V or 2.9V	SIM RESET
E46	/SIM_DATA	SIM	1.8V or 2.9V	SIM DATA
E47	VSIM	SIM	1.8V or 2.9V	VSIM
E48	VBATT	POWER	3.7V	VBATT
E49	GND	POWER	0V	0V
E50	/HSET_OUT_P	AUDIO	3.7V	Left Open
E51	/HSET_OUT_N	AUDIO	3.7V	Left Open

5. ELECTRICAL SPECIFICATION

Five system operating states are defined:

- NO SUPPLY: No power voltage is present.
- BACKUP: Only backup battery is present.
- OFF: Main power voltage is present, backup voltage present or not.
- ACTIVE: Main power voltage is present, backup battery present or not. Internal power supplies are on.
- SLEEP: Main power voltage is present, backup battery present or not. Internal power supplies are in low power mode.

If not specified, all electrical values are given for the active state at VBAT=3.7V and an operating temperature of 25°C.

5.1 VBAT

The module is supplied through the VBAT signal with the following characteristics:

Parameter	Name	Min	Typ	Max
VBAT period (ms)	VbatTe ⁽¹⁾	4.614	4.615	DC
VBAT low duration (us)	VbatTi ⁽¹⁾	550	-	VBAT period
VBAT rise time (us)	VbatTr ⁽¹⁾	0	-	-
VBAT fall time (us)	VbatTf ⁽¹⁾	0	-	-
VBAT maximum voltage (V)	VbatMax ⁽¹⁾	-	-	4.5
VBAT minimum voltage (V)	VbatMin ⁽¹⁾	3.2	-	-
VBAT drop voltage (mV)	DeltaVbat ⁽¹⁾	-	-	300 ⁽²⁾
Transient voltage (V)		2.9	-	-
Noise level (Vrms)@100KHz-1MHz		-	-	50mV

⁽¹⁾ cf. Figure 7. and Application Notes for more details.

⁽²⁾ This value depends on the power supply serial resistor (plus contact and tracks serial resistors)

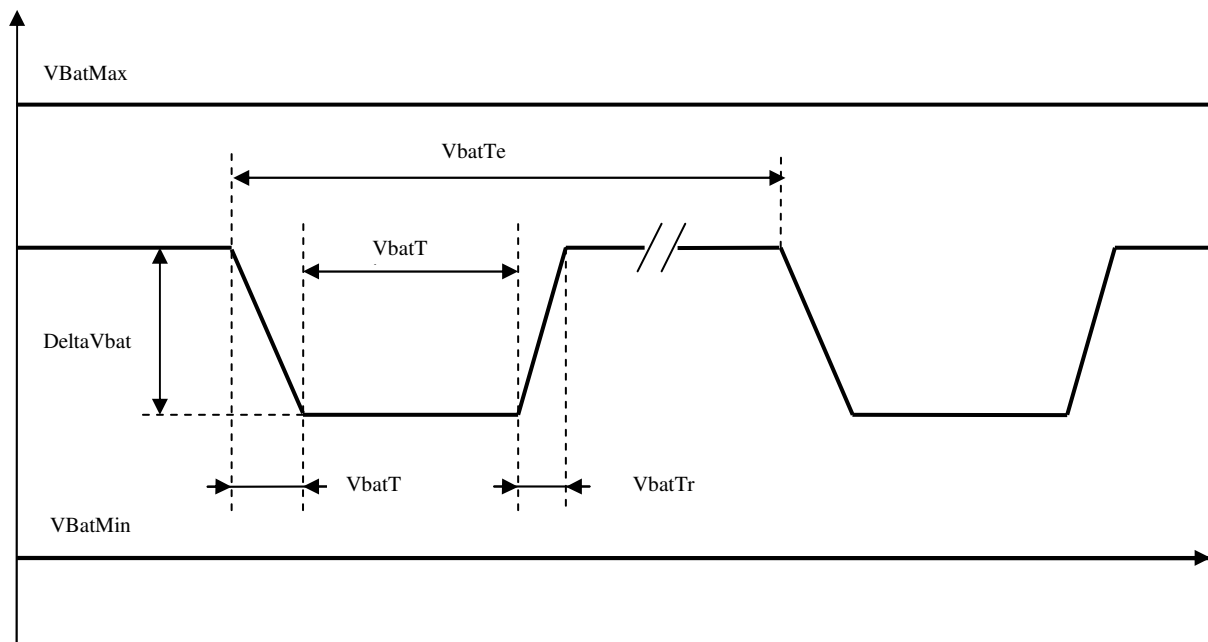

Figure 7: VBAT voltage waveform

5.2 VGPIO

Parameter	Min	Typ	Max	Remarks
Voltage level(V)	2.65	2.80	2.95	Both active mode and sleep mode
Current capability active mode(mA)	-	-	50	
Current capability sleep mode(mA)	-	-	3	32KHz system clock enable
Line regulation(mV/V)	-	-	50	Iout = MAX
Rise Time(ns)	-	-	6	Test load capacitor = 30 pF

5.3 VBACKUP

Parameter	Min	Typ	Max	Remarks
Voltage level(V)		3		

5.4 VSIM

Parameter	Min	Typ	Max	Remarks
Output Voltage(V)	2.75	2.90	3.0	The appropriate output voltage is auto detected and selected by software
	1.65	1.80	1.95	
Output Current(mA)	-	-	10	In sleep mode Max output current = 3 mA
Line Regulation(mV/V)	-	-	50	IOOUT = MAX
Powerup Setting Time(us) from Power down	-	10	-	

5.5 DIGITAL INTERFACE

The digital interface has the following characteristics, which includes UARTS, RF burst Indicator, Digital audio PCM, PWM and GPIOs.

Parameter	Min	Typ	Max	Remarks
Input Current-High(μ A)	-10	-	10	
Input Current-Low(μ A)	-10	-	10	
DC Output Current-High(mA) ⁽¹⁾	-	-	15	Pad driving a "1" with output set at "0"
DC Output Current-Low(mA) ⁽¹⁾	-15	-	-	Pad driving a "0" with output set at "1"
Input Voltage-High(V)	2.4			
Input Voltage-Low(V)	-	-	0.4	
Output Voltage-High(V)	2.7	-	-	
Output Voltage-Low(V)	-	-	0.1	

⁽¹⁾ The maximum current for one GPIO is 15mA, but all GPIOs can not provide 15mA at a time since the VIO is limited to 50mA

5.6 POK_IN

The POK_IN signal has the following characteristics:

Parameter	Min	Type	Max
Input Voltage-Low(V)		-	0.4
Input Voltage-High(V)	2.4	-	3.3V
Powerup Period (ms) from POK_IN falling edge	2000	-	-

5.7 RESET

The RESET signal has the following characteristics:

Parameter	Min	Type	Max
Input Voltage-Low(V)		-	0.4
Input Voltage-High(V)	2.4	-	
Power up Period (ms) from RESET falling edge	38	-	-

5.8 SIM

Signal	VL (V)		VH (V)	
	Min	Max	Min	Max
SIM_RST	Fully compliant to the GSM11.11 and ISO/IEC 7816-3 standards			
SIM_CLK				
SIM_DATA				

5.9 PWM

Two PWMs have the following characteristics

Signal	Frequency		Duty (%)		Remarks
	Min	Max	Min	Max	
PWM0 and PWM1 ⁽¹⁾	25.6KHz	1083.3KHz	0	100	

⁽¹⁾ General purpose PWMs with push pull output, an external transistor (NMOSFET) is required for driving buzzer, backlight...

The buzzer PWM has the following characteristics:

Signal	Frequency		Remarks
	Min	Max	
PWM2 ⁽²⁾	243Hz	250KHz	

⁽²⁾ PWM dedicated for driving buzzer.

It can't be used as a standard PWM. The average value is always 1.42V as it cannot be fixed to one specific level; this signal is always switching from high to low level.

5.10 AUX_ADC

The Auxiliary ADC has the following characteristics. A detailed description of the AT command is given in [1].

Parameter	Min	Typ	Max	Remarks
ADC Resolution(bits)	-	10	-	
Num of Inputs	-	-	1	
Input Voltage Range(V)	0	-	1	1 general purpose input
	0	-	3	1 general purpose input in div-by-3 mode
	0	-	5.5	battery voltage input
	4.2	-	5.5	battery voltage input (zoom)
Update rate per channel(kHz)	-	-	200	
Differential Nonlinearity(bits)	-1	-	+3	
Integral Nonlinearity(bits)	-2.5	-	+2.5	
Offset Error(mV)	-	5	-	
Gain Error(mV/LSB)	-	0.02	-	
Input Resistance (kΩ)	120	150	-	
Input Capacitance (pF)	-	-	10	

5.11 UART1

TXD, RXD, CTS, RTS, DCD, DSR, DTR and RI have the following characteristics:

Signal	V _L (V)		V _H (V)	
	Min	Max	Min	Max
UART1_TX		0.1	2.7	3.2
UART1_RX		0.4	2.4	3.2
UART1_RTS		0.4	2.4	3.2
UART1_CTS		0.1	2.7	3.2
UART1_DCD		0.1	2.7	3.2
UART1_DTR		0.4	2.4	3.2
UART1_DSR		0.1	2.7	3.2
UART1_RI		0.1	2.7	3.2

5.12 ANALOG AUDIO SIGNALS

5.12.1 Analog Audio Inputs

The audio inputs contain the following characteristics:

Parameter	Min	Typ	Max	Test Conditions
Maximum input range		1.4V		With Gain = - 6dB
Nominal reference level		16mV		Typical value Gain = + 34dB
Input Micro amplifier gain (dB)	-6		+ 50	

5.12.2 Analog Audio Outputs

The audio outputs contain the following characteristics:

Parameter	Min	Typ	Max	Test Conditions
Maximum output range		1.65 Veff		Load=32Ω, THD=1%, Output gain = 8 dB
Load resistance (Ω)		32		
Output amplifier gain (dB)	-28	-	8	

5.13 RF SIGNALS

5.13.1 Load mismatch

The module accept a VSWR < 20:1 (all phase angles) without damage or permanent degradation
 The module accept a VSWR < 12:1 (all phase angles) without any spurious emission > - 30 dBm

5.13.2 Input VSWR

The typical input VSWR is 1.5:1 (max = 1.5:1)

5.13.3 Antenna matching network

A matching network in HiLoNC V2 is optimized for 50 ohm work load.

To get good performance in application, an additional matching circuit and adjustment for actual antenna is required. A π -type matching network is recommended in HiLoNC V2 application note [2].

6. ENVIRONMENTAL SPECIFICATION

Parameter	Min	Max
Ambient temperature range	-40 °C	+85 °C
Storage temperature	-40 °C	+85 °C
Long damp heat Operating conditions	Tested at +60 °C, 95% during 504 hours	
Short damp heat Storage and transportation conditions	Tested at +40 °C, 95% RH during 96 hours	

6.1 NORMAL TEMPERATURE RANGE

ETSI performances are guaranteed by Sagemcom in the range of -40 °C to +85 ° C.

6.1.1 Sensitivity

Frequency band	GSM850		EGSM		ETSI value
	-40	+85	-40	+85	
Temperature (°C)	-40	+85	-40	+85	
Typical sensitivity (dBm)	-109	-107	-109	-107	< -102

Frequency band	DCS		PCS		ETSI value
	-40	+85	-40	+85	
Temperature (°C)	-40	+85	-40	+85	
Typical sensitivity (dBm)	-108	-106	-108	-106	< -102

6.1.2 Power consumption

See §3.7.2

6.2 OUT OF OPERATIONAL RANGE

No operation is guaranteed by Sagemcom out of the extended range. However, it has been observed on several modules.

Temperature range	Comments
-50 °C to -40 °C and +85 °C to 125 °C	HiLoNC V2 modules keeps the communication without any anomaly
125 °C to 150 °C	No permanent damage is observed but some modules reboot themselves
T = 150 °C	The flash memory may be erased and the module has to be retrofitted
T < -50 °C and T > 150 °C	No test has been performed

7. ESD

Using human body model from JEDEC JESD 22-A114 standard, the HiLoNC V2 can stand for +/-2kV ESD on all the 51 pads.

8. MTBF

HiLoNC V2 MTBF calculated according to two couple of standards / mission profiles.

8.1 RESULTS

	TELECOM PROFILE	AUTOMOTIVE PROFILE
Temperature	+25 °C	+40 °C
HILONC V2 MTBF (hours)	9 009 009 (111 fits)	762 776 (1311 fits)

8.2 AUTOMOTIVE PROFILE (PRODUCT IN PASSENGER COMPARTMENT).

Mission profiles described hereinafter correspond to the MIL-HDBK-217F “Ground; mobile” environment.

Several working phases are considered.

- The working rates consider three different internal working temperatures for the equipment, and take into account the annual working hours for each of these temperatures. The overall working time is estimated to be 500 h
- Two thermal cycling are considered:
 - Phase 1: 2 night starts;
 - Phase 2: 4 day light starts;
 - Phase 3: non-used vehicle, dormant mode 30 days per year.

Mission profile phases	Temp. 1		Temp.2		Temp. 3		Ratios on/off		2 night starts		4 day light starts		Non used vehicle	
	(t_{ac}) ₁ °C	τ_1	(t_{ac}) ₂ °C	τ_2	(t_{ac}) ₃ °C	τ_3	τ_{on}	τ_{off}	n_1	ΔT_1	n_2	ΔT_2	n_3	ΔT_3
Motor control	32	0.02	60	0.015	85	0.023	0.058	0.942	670	$\frac{\Delta T_j}{3} + 55$	1340	$\frac{\Delta T_j}{3} + 4$	30	10
Passenger compartment	27	0.006	30	0.046	85	0.006	0.058	0.942	670	$\frac{\Delta T_j}{3} + 30$	1340	$\frac{\Delta T_j}{3} + 20$	30	10

8.3 TELECOM PROFILE (GROUND NON STATIONARY SEVERE).

This MTBF is calculated with RDF2000 standard and the following parameters

- Room temperature: $T_{ac} = 25$ °C
- Average temperature at components vicinity: $T_{ae} = 25$ °C
- Time of operation: 100%
- Transmission mode: 1%
- Idle mode: 99%
- Thermal cycles per year: 365
- Temperature change between day and night: $\Delta T = 0$ °C

9. MECHANICAL SPECIFICATION

9.1 DESCRIPTION

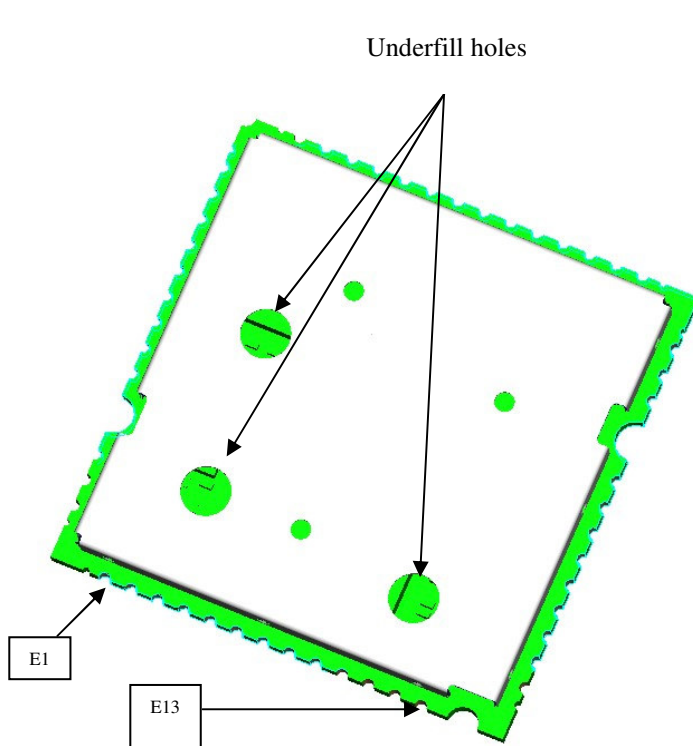

Figure 8: HiLoNC V2 top view

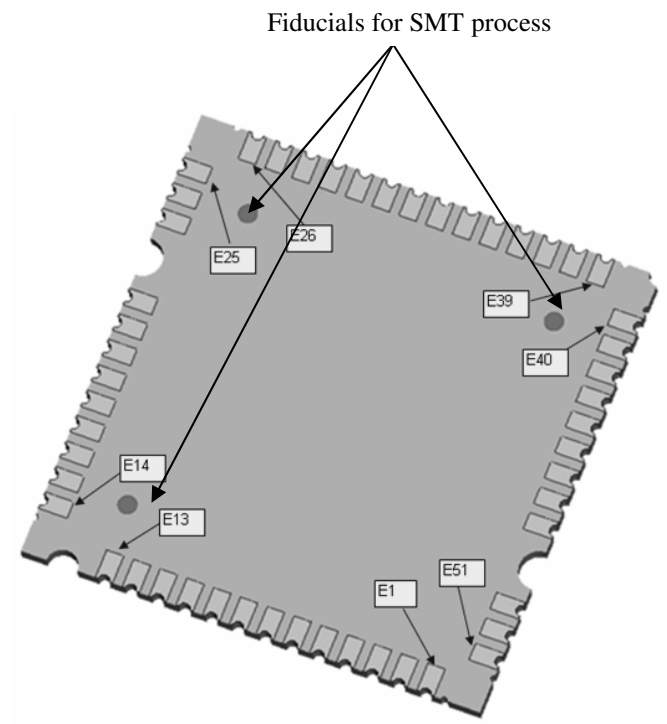

Figure 9: HiLoNC V2 bottom view

E1 to E51 corresponds to the 51 pads around the module : all input and output signals including antenna signal.

9.2 PHYSICAL DIMENSIONS

Notes: All dimensions are in millimeter.

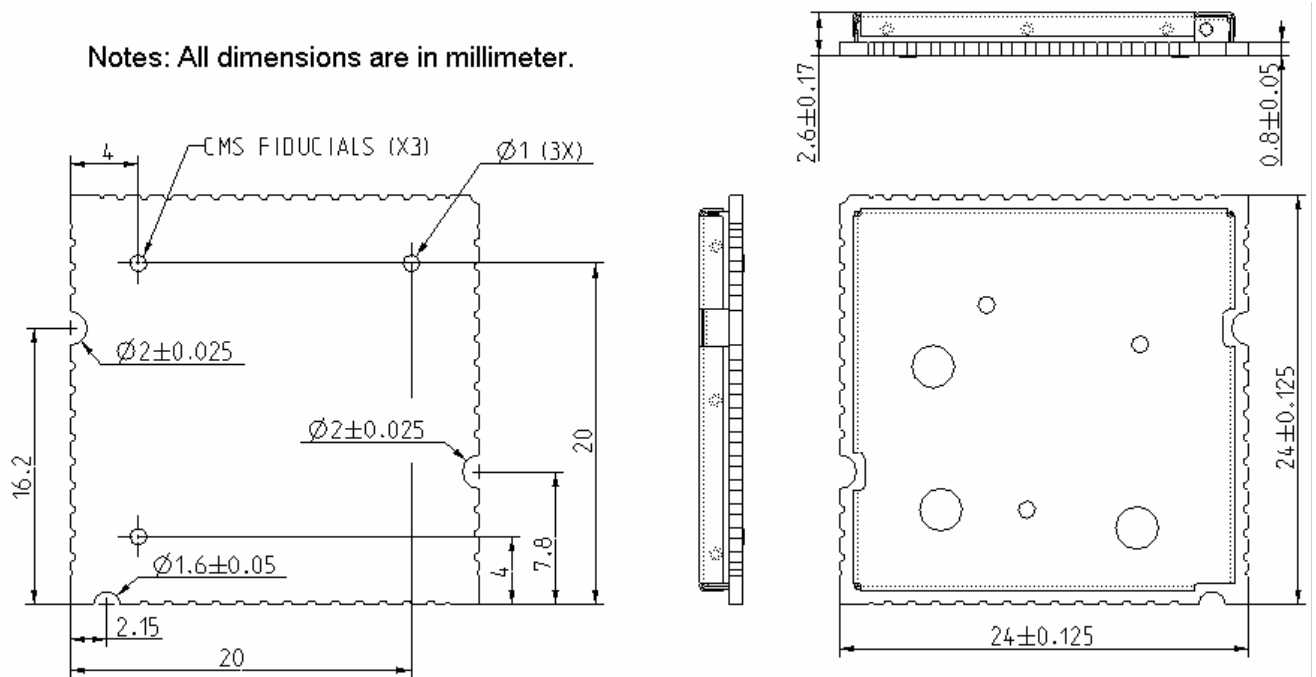

Figure 10: HiLoNC V2 dimensions

9.3 DECOMPOSITION

Shield frame is soldered on HiLoNC V2 PCB; Shield cover is assembled with shield frame and is removable. Decomposition is detailed in the figure below.==> *To be updated with the new internal shield frame design.*

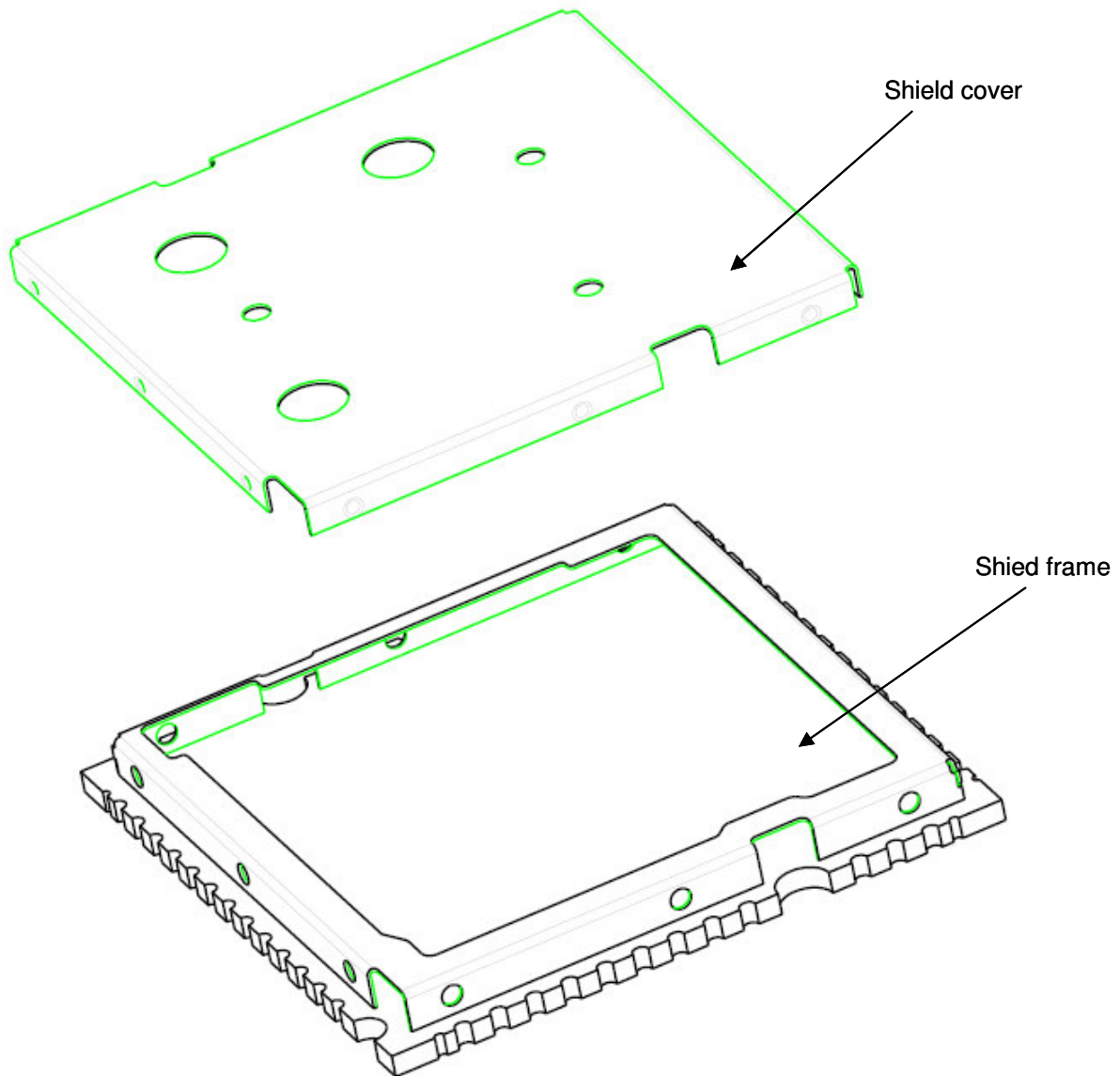

Figure 11: HiLoNC V2 decomposition

10. CUSTOMER PROCESS

10.1 FOOTPRINT

This HiLoNC V2 module is directly soldered on the customer board through its 51 pads. The recommended footprint for the customer board is given in the figure below.

No component and no via must be present under the HiLoNC V2 module.

Notes: All dimensions are in millimeter.

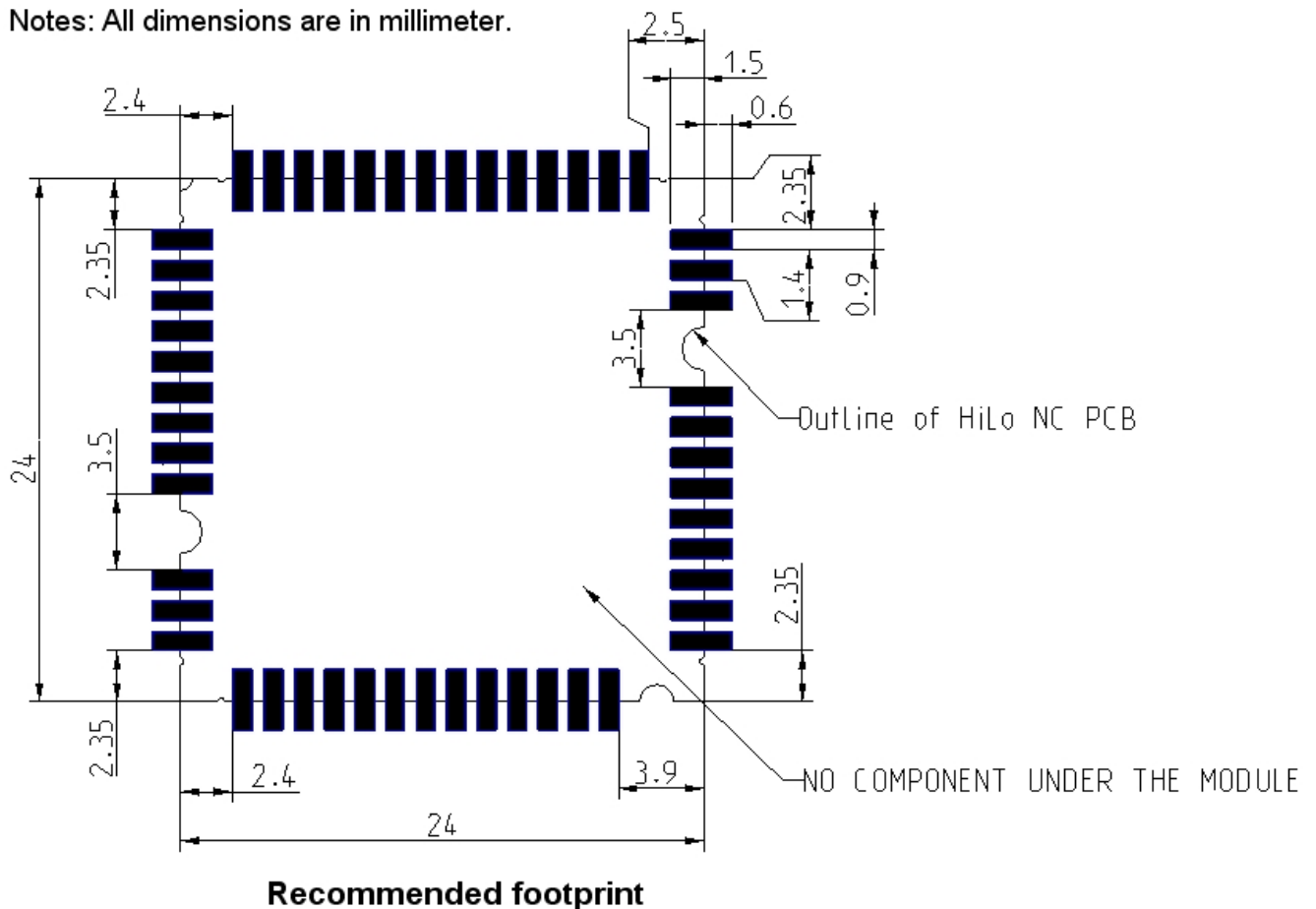

Figure 12: HiLoNC V2 Footprint on mother board

10.2 PACKAGING

The HiLoNC V2 is provided in Tape and Reel packaging to be mounted in fully automatic SMT process with standard pick-and place-equipment.
More details about the T&R characteristics are given in the HiLoNC V2 application note [2].

10.3 MSL

According to IPC/JEDEC J-STD 20, the HiLoNC V2 has the following MSL level : 3 .

Following conditions must then be respected.

Level	Floor Life		Soak requirements			
			Standard		Accelerated Equivalent	
	Time	Conditions	Time (hours)	Conditions	Time (hours)	Conditions
3	168 hours	<= 30°C/60% RH	192 +5/-0	30°C / 60% RH	40 +1/-0	60°C / 60%RH

10.4 SOLDER PROCESS

Recommendations are given in the application note regarding solder process, solder composition. HiLoNC V2 is optimized for SMT process and mass-production. Nevertheless, hand-soldering is also possible and detailed in the application note.

10.5 UNDERFILL

Despite its important reliability, some customer could request for some specific and extreme applications the underfill of onboard components. The HiLoNC V2 module has then been designed to allow its underfill. More details are given in the HiLoNC V2 application note [2].

11. ORDERING AND CONTACT INFORMATION

11.1 PART NUMBER

Module :

253356774 MODULE HILONC V2 SP QBM

This reference includes the most recent software and generic parameters

11.2 CONTACT

Email : wireless-modules@sagem.com

Web : <http://www.sagemcom.com/>

SAGEMCOM,
Wireless M2M Modules
250, route de l'empereur
92848 Rueil-Malmaison Cedex
FRANCE

12. REFERENCE DOCUMENTS

-
- [1] URD1 OTL 5635.1 008 70248 - AT Command Set for SAGEMCOM Hilo HiloNC Modules
 - [2] URD1 OTL 5665.3 003 72238 - HiLoNC V2 Application Note
 - [3] Getting started – How to manage DTR

Sagemcom Energy & Telecom SAS

Siège social : 250, route de l'Empereur - 92848 RUEIL-MALMAISON CEDEX - FRANCE
Tél. +33(0)1 57 61 10 00 - Fax : +33 (0)1 57 61 10 01

S.A.S. au capital de 44 824 840 € - 518 250 337 RCS Nanterre
www.sagemcom.com